



Agilent Components

2	Introduction
3	Vacuum Express
4-44	ConFlat Flanges and Fittings
45	Wheeler Flanges
46-76	Klamp Flanges and Fittings
77-93	ISO Flanges and Fittings
94-95	Feedthroughs
96-98	Supplies

Flanges

- Superior Quality Construction
- High Reliability
- Immediate Delivery

Agilent Vacuum Flanges and Fittings



ConFlat Flanges & Fittings

Agilent's ConFlat Flanges have set the industry standard for vacuum flange performance. These flanges are available in rotatable and non-rotatable models, and in sizes from 1.33 in. to 13.25 in. OD.

Agilent utilizes unique manufacturing processes and techniques to ensure leak-free performance in ConFlat Flanges. Our unbending commitment to quality assures you of trouble-free vacuum performance of the Agilent ConFlat Flange.



Klamp Flanges & Fittings

Designed in accordance with ISO standards the Agilent KF flange can be used in a variety of applications from atmospheric pressure to high vacuum. The KF flange is manufactured from 304 stainless steel and has a leak rate less than 1E-9 std cc/sec and can be baked to 150 °C when using a Viton O-Ring.

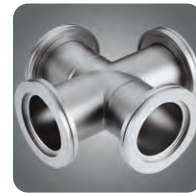

ISO Flanges & Fittings

ISO flanges and fittings are designed for applications requiring frequent disassembly and where tubing requirements generally exceed 2 in. OD. All ISO flanges and fittings listed are made of 304L stainless steel. These flanges can be used in a variety of applications from atmospheric to E⁻⁸ Torr. They can sustain a bakeout temperature of 150 °C when using Viton o-rings.



Feedthroughs

Rotary motion feedthrough.
High voltage feedthrough.



Supplies

Greases and lubricants.
Diffusion and mechanical pump fluids.

VacuumXpress

Your vacuum hardware order shipped in **24** hours or less!



Ordering

- Flanges and fittings can be ordered by calling Agilent directly, or through your local Agilent Sales Engineer or Representative
- Select flanges and fittings can also be ordered on-line through Agilent's web-site

Delivery

- Hundreds of popular vacuum components in stock
- We ship from our Lexington, MA facility within 24 hours... or we will deliver your order at your convenience

Quality

- High Quality ConFlat, ISO, and KF Flanges and Fittings
- Agilent's State-of-the-Art Manufacturing and Distribution Facility
- Efficient, reliable, quality manufacturing processes and techniques including Statistical Process Control (SPC) and Process Capability Index (CpK)

ConFlat Flanges

Agilent ConFlat Flanges

Agilent's ConFlat Flanges have set the industry standard for vacuum flange performance. These flanges are available in rotatable and non-rotatable models, and in sizes from 1.33 in. to 13.25 in. OD.

Agilent utilizes unique manufacturing processes and techniques to ensure leak-free performance in ConFlat Flanges. Our flanges are manufactured from type 304 ESR or 304L stainless steel. ESR stainless steel is manufactured using a process known as Electro Slag Remelting. This process is a further refinement of the stainless steel and results in higher purity, fewer inclusions, a more uniform grain structure, and generally improved properties. Electro Slag Remelting also markedly reduces non metallic inclusions, oxygen content, sulfur, and micro and macro segregations.

304 ESR flanges are recommended for electro-plating applications when the flanges are not masked-off.

Each lot of raw material is carefully evaluated for performance prior to use in manufacturing. Only upon acceptance will this material be used for ConFlat Flange production. Our unbending commitment to quality assures you of trouble-free vacuum performance of the Agilent ConFlat Flange.

Agilent ConFlat Flange Fittings

A large variety of fittings are immediately available for your vacuum application. Agilent's ConFlat Flange vacuum fittings offer the same vacuum performance as our ConFlat Flange. Combined with our excellence in vacuum component fabrication, these fittings offer high reliability and performance for your application.



Specifications

Materials

Flanges: ConFlat Flange are available in 304L Stainless Steel and 304 Stainless Electro-Slag Remelt (ESR). Larger flanges may be made from open-die or cross-forged type 304 Stainless. Rotatable flanges in ESR may include receivers made from 304 bar or plate.

Other materials, such as 316LN SS, are also available.

Gaskets: Copper gaskets are made from electronic grade OFHC copper with a "Purity Total" of greater than 99.99%.

Viton Gaskets: Reusable gaskets for leak checking and use in unbaked applications are also available.

Hardware: Bolt options include 12-point high tensile strength, hexagonal head, or metric hexagonal head. Washers are not required with 1.33 in. (NW16 CF) and 2.75 in. (NW25 CF) OD flanges.

Performance

Vacuum Range: Atmospheric to 1×10^{-13} Torr (mbar). No leak detectable on mass spectrometer leak detector with sensitivity of 2×10^{-10} std cc/sec.

Temperature Range: 304 ESR SS can be repeatedly cycled from -196° C to $+500^{\circ}$ C.

Packaging: All Agilent components are cleaned via an ultrasonic aqueous base cleaning system using de-ionized water. Water soluble coolants and non-sulphur based compounds are used in our manufacturing processes. Our parts are free of visible particulates, debris, oils and greases, and are ready for use in vacuum systems.

Components

Agilent's introduction of its extensive offering in vacuum flanges and fittings features an intuitive part numbering format. These part numbering format allows the customer to identify the product by the characters contained within the part number.

Depending on the product, the number and format of the characters in the part number will vary.

Please see the examples below:

CFF Example

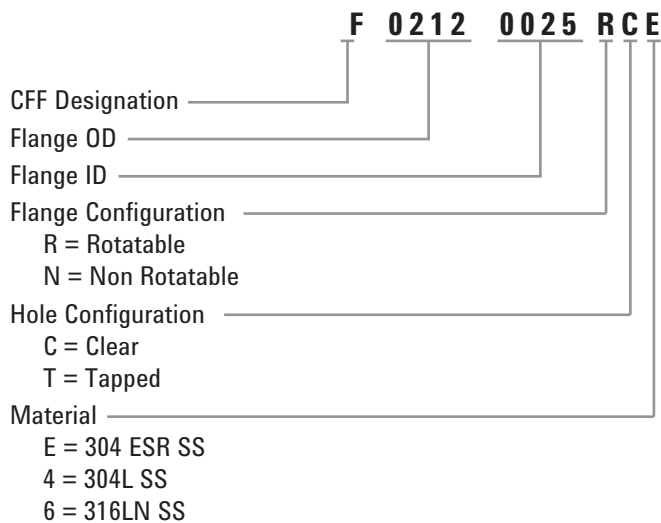

CFF Nipple Example



ConFlat Flanges & Fittings

	Page
ConFlat Flanges	6
Reducing Flanges	24
ConFlat Flange Accessory Dimensions	26
Bolt/Nut Sets – Reducing Flanges	27
Bolt Torques	27
Reducing Nipples – 304 Steel and 316LN SS.....	28
Half Nipples	29
Nipples	30
Elbows (90°)	31
Tees	32
Crosses (4-Way)	32
Flexible Couplings	33
CFF to KF Adapters	35
UHV Compression Ports.....	38
ConFlat to Compression Port Adapters.....	39
O-Ring Sealed Vacuum Compression Ports and Blank-offs	40
Viewports.....	41
Glass Adapters.....	44

Wheeler Flanges

	Page
UHV Wire-sealed flanges.....	45

ConFlat Flanges

1 1/3 in. (NW16CF) Non-Rotatable

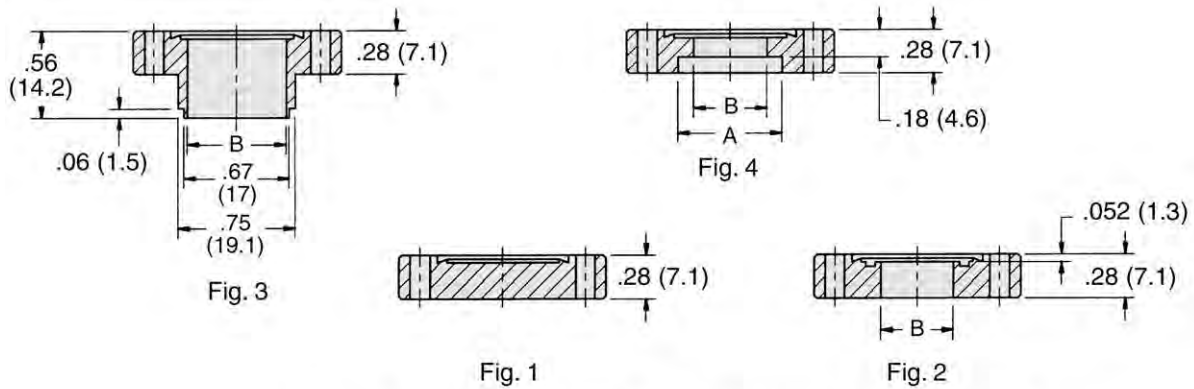

Thru holes: 6 holes .172 (4.4) dia. thru, eq. spaced on 1.062 (26.9) dia. B.C.
Tapped holes: 6 holes tapped 8-32 thru, eq. spaced on 1.062 (26.9) dia. B.C.

Dimensions: inches (millimeters)

Ordering Information

Type	304L SS Part Number	304 ESR SS Part Number	Fig. Number	Dimensions		Weight lbs (kg)
				A in. (mm)	B in. (mm)	
Non-Rotatable	F01330000NC4	F01330000NCE	1	—	—	0.5 (0.2)
	F01330025NC4	F01330025NCE	2	—	0.26 (6.48)	0.5 (0.2)
	F01330038NC4	F01330038NCE	2	—	0.38 (9.70)	0.5 (0.2)
	F01330050NC4	F01330050NCE	2	—	0.51 (12.82)	0.5 (0.2)
	F01330075NC4W	F01330075NCEW	3	—	0.63 (16.00)	0.5 (0.2)
	F01330075NC4B	F01330075NCEB	4	0.76 (19.20)	0.63 (16.00)	0.5 (0.2)
Non-Rotatable Tapped	F01330000NT4	F01330000NTE	1	—	—	0.5 (0.2)
	F01330025NT4	N/A	2	—	0.26 (6.48)	0.5 (0.2)
	F01330038NT4	N/A	2	—	0.38 (9.70)	0.5 (0.2)
	F01330050NT4	N/A	2	—	0.51 (12.82)	0.5 (0.2)
	F01330075NT4W	F01330075NTEW	3	—	0.63 (16.00)	0.5 (0.2)
	F01330075NT4B	F01330075NTEB	4	0.76 (19.20)	0.63 (16.00)	0.5 (0.2)

Accessories

Description	Copper Part Number	Silver Plated Copper Part Number	Viton Part Number	Qty/Pkg	Weight lbs (kg)
Gaskets					
10-pack, individually sealed	FG0133CI	FG0133CIS	N/A	10	1.0 (0.5)
Package set	N/A	N/A	FG0133VU	5	0.5 (0.2)
Gasket clip set	GC0275S	N/A	N/A	10	0.5 (0.2)

1 1/3 in. (NW16CF) Rotatable

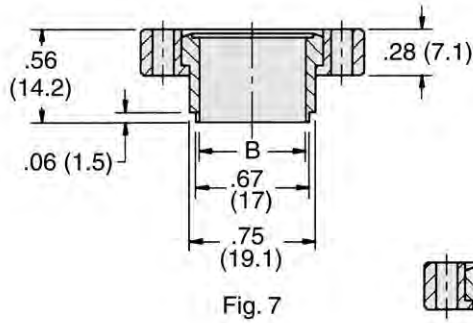

Fig. 7

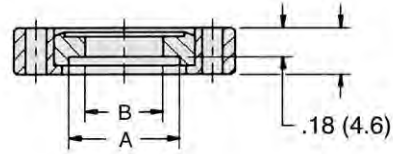

Fig. 8

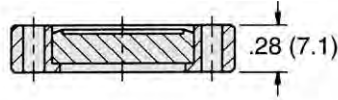

Fig. 5

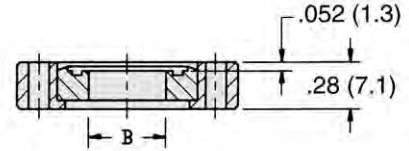

Fig. 6

Thru holes: 6 holes .172 (4.4) dia. thru, eq. spaced on 1.062 (26.9) dia. B.C.
Tapped holes: 6 holes tapped 8-32 thru, eq. spaced on 1.062 (26.9) dia. B.C.

Dimensions: inches (millimeters)

Ordering Information

Type	304L SS Part Number	304 ESR SS Part Number	Fig. Number	Dimensions		Weight lbs (kg)
				A in. (mm)	B in. (mm)	
Rotatable	F01330000RC4	F01330000RCE	5	—	—	0.5 (0.2)
	F01330025RC4	N/A	6	—	0.26 (6.48)	0.5 (0.2)
	F01330038RC4	F01330038RCE	6	—	0.38 (9.70)	0.5 (0.2)
	F01330050RC4	F01330050RCE	6	—	0.51 (12.82)	0.5 (0.2)
	F01330075RC4W	F01330075RCEW	7	—	0.63 (16.00)	0.5 (0.2)
	F01330075RC4B	F01330075RCEB	8	0.76 (19.20)	0.63 (16.00)	0.5 (0.2)
Rotatable	N/A	F01330000RTE	5	—	—	0.5 (0.2)
Tapped	F01330075RT4W	N/A	7	—	0.63 (16.00)	0.5 (0.2)

Accessories

Description	Thread/Length	Socket Head Part Number	Silver Plated Socket Head Part Number	Qty/Pkg	Weight lbs (kg)
Nut and Bolt Sets					
Clear hole flanges*	8-32 x 3/4	FB0133C	FB0133CS	25	2.0 (0.9)
Tapped hole flanges**	8-32 x 1/2	FB0133T	FB0133TS	25	1.0 (0.5)
Plate Nut Sets					
12 plate nuts/24 bolts/washers		FP0133K	N/A	12/24	2.0 (0.9)
24 plate nuts only		FP0133N	N/A	24	1.0 (0.5)

* Includes nuts, washers, and bolts

** Includes washers and bolts only

NOTE * Custom configurations available on request

ConFlat Flanges

2³/₄ in. (NW35CF) Non-Rotatable

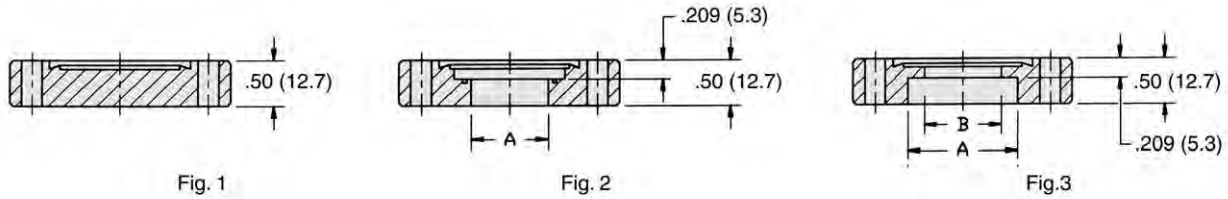

Thru holes: 6 holes .265 (6.7) dia. thru, eq. spaced on 2.312 (58.7) dia. B.C.

Tapped holes: 6 holes tapped 1/4-28 thru, eq. spaced on 2.312 (58.7) dia. B.C.

Dimensions: inches (millimeters)

Ordering Information

Type	304L SS Part Number	304 ESR SS Part Number	Fig. Number	Dimensions		Weight lbs (kg)
				A in. (mm)	B in. (mm)	
Non-Rotatable	F02750000NC4	F02750000NCE	1	—	—	0.8 (0.4)
	F02750025NC4W	N/A	2	0.26 (6.48)	—	0.8 (0.4)
	F02750050NC4W	N/A	2	0.51 (12.83)	—	0.8 (0.4)
	F02750075NC4B	N/A	3	0.76 (19.30)	0.69 (17.53)	0.8 (0.4)
	F02750075NC4W	F02750075NCEW	2	0.76 (19.30)	—	0.8 (0.4)
	F02750100NC4B	F02750075NCEB	3	1.01 (25.65)	0.88 (22.23)	0.5 (0.2)
	F02750100NC4W	F02750100NCEW	2	1.01 (25.65)	—	0.8 (0.4)
	F02750125NC4	F02750125NCE	3	1.26 (32.00)	1.13 (28.56)	0.5 (0.2)
	F02750150NC4	F02750150NCE	3	1.51 (38.35)	1.38 (34.93)	0.5 (0.2)
	F02750162NC4	N/A	3	1.64 (41.53)	1.50 (38.10)	0.5 (0.2)
	F02750175NC4	F02750175NCE	3	1.76 (44.70)	1.63 (41.28)	0.5 (0.2)
	Non-Rotatable Tapped	F02750000NT4	F02750000NTE	1	—	—
F02750025NT4W		N/A	2	0.26 (6.48)	—	0.8 (0.4)
F02750050NT4W		N/A	2	0.51 (12.83)	—	0.8 (0.4)
F02750075NT4B		N/A	3	0.76 (19.30)	0.69 (17.53)	0.8 (0.4)
F02750075NT4W		N/A	2	0.76 (19.30)	—	0.8 (0.4)
F02750100NT4B		N/A	3	1.01 (25.65)	0.88 (22.23)	0.5 (0.2)
F02750100NT4W		N/A	2	1.01 (25.65)	—	0.8 (0.4)
F02750125NT4		F02750125NTE	3	1.26 (32.00)	1.13 (28.56)	0.5 (0.2)
F02750150NT4		F02750150NTE	3	1.51 (38.35)	1.38 (34.93)	0.5 (0.2)
F02750162NT4		N/A	3	1.64 (41.53)	1.50 (38.10)	0.5 (0.2)
F02750175NT4		N/A	3	1.76 (44.70)	1.63 (41.28)	0.5 (0.2)

Accessories

Description	Copper Part Number	Silver Plated Copper Part Number	Viton Part Number	Qty/Pkg	Weight lbs (kg)
Gaskets					
10-pack, individually sealed	FG0275CI	FG0275CIS	N/A	10	0.5 (0.2)
10-pack, solid blank-off	FG0275CUB	N/A	N/A	10	1.0 (0.5)
Package set	N/A	N/A	FG0275VU	5	0.5 (0.2)
Gasket clip set	GC0275S	N/A	N/A	10	0.5 (0.2)

2³/₄ in. (NW35CF) Rotatable

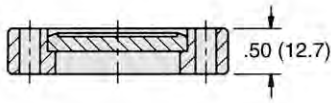

Fig. 4

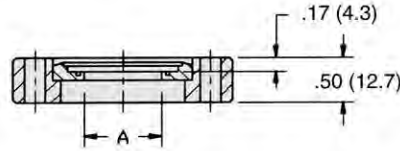

Fig. 5

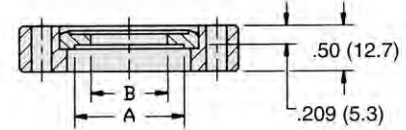

Fig. 6

Dimensions: inches (millimeters)

Thru holes: 6 holes .265 (6.7) dia. thru, eq. spaced on 2.312 (58.7) dia. B.C.
Tapped holes: 6 holes tapped 1/4-28 thru, eq. spaced on 2.312 (58.7) dia. B.C.

Ordering Information

Type	304L SS		Fig. Number	Dimensions		Weight lbs (kg)
	Part Number	304 ESR SS Part Number		A in. (mm)	B in. (mm)	
Rotatable	F02750000RC4	F02750000RCE	4	—	—	0.8 (0.4)
	F02750025RC4	N/A	5	.26 (6.48)	—	0.8 (0.4)
	F02750050RC4	N/A	5	.51 (12.83)	—	0.8 (0.4)
	F02750075RC4	N/A	6	.76 (19.30)	.63 (16.00)	0.8 (0.4)
	F02750100RC4	F02750100RCEB	6	1.01 (25.65)	.88 (22.23)	0.5 (0.2)
	N/A	F02750100RCEV	5	1.01 (25.65)	—	0.8 (0.4)
	F02750125RC4	F02750125RCE	6	1.26 (32.00)	1.13 (28.56)	0.5 (0.2)
	F02750150RC4	F02750150RCE	6	1.51 (38.35)	1.38 (34.93)	0.5 (0.2)
	F02750162RC4	N/A	6	1.65 (41.53)	1.50 (38.10)	0.5 (0.2)
	F02750175RC4	N/A	6	1.76 (44.70)	1.63 (41.28)	0.5 (0.2)

NOTE * Custom configurations available on request

See page 16 for Accessories Ordering Information

Accessories

Description	Thread/Length	Hex Head Part Number	12-Point Bolt Part Number	Silver Plated 12-Point Bolt Part Number	Qty/Pkg	Weight lbs (kg)
Nut and Bolt Sets						
Clear hole flanges*	1/4-28 x 1 1/4	FB0275C06	FB0275C12	FB0275C12S	25	1.0 (0.5)
Tapped hole flanges**	1/4-28 x 7/8	FB0275T06	FB0275T12	FB0275T12S	25	0.5 (0.2)
Plate Nut Sets						
12 plate nuts/24 bolts/24 washers		FP0275K06	FP0275K12	N/A	12/24	2.0 (0.9)
24 plate nuts only		FP0275N	N/A	N/A	12/24	2.0 (0.9)

* Includes nuts, washers, and bolts

** Includes washers and bolts only

NOTE * Custom configurations available on request

ConFlat Flanges

3³/₈ in. (NW50CF) Non-Rotatable

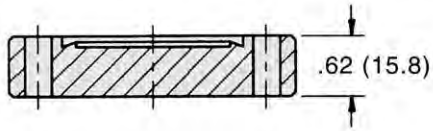

Fig. 1

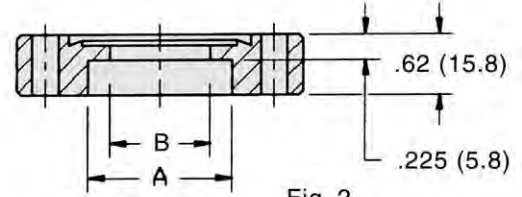

Fig. 2

Thru holes: 8 holes .332 (8.4) dia. thru, eq. spaced on 2.850 (72.4) dia. B.C.
 Tapped holes: 8 holes tapped 5/16-24 thru, eq. spaced on 2.850 (72.4) dia. B.C.

Dimensions: inches (millimeters)

Ordering Information

Type	304L SS Part Number	304 ESR SS Part Number	Fig. Number	Dimensions		Weight lbs (kg)
				A in. (mm)	B in. (mm)	
Non-Rotatable	F03380000NC4	N/A	1	—	—	2.0 (0.9)
	F03380150NC4	N/A	2	1.51 (38.35)	1.38 (34.93)	1.5 (0.7)
	F03380200NC4	N/A	2	2.01 (51.18)	1.88 (47.63)	1.5 (0.7)
Non-Rotatable	F03380000NT4	N/A	1	—	—	2.0 (0.9)
Tapped	F03380150NT4	N/A	2	1.51 (38.35)	1.38 (34.93)	1.5 (0.7)
	F03380200NT4	N/A	2	2.01 (51.18)	1.88 (47.63)	1.5 (0.7)

Components

3³/₈ in. (NW50CF) Rotatable

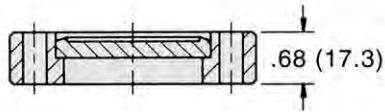

Fig. 3

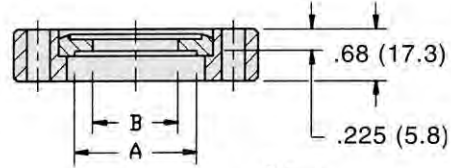

Fig. 4

Thru holes: 8 holes .332 (8.4) dia. thru, eq. spaced on 2.850 (72.4) dia. B.C.
Tapped holes: 8 holes tapped 5/16-24 thru, eq. spaced on 2.850 (72.4) dia. B.C.

Dimensions: inches (millimeters)

Ordering Information

Type	304L SS Part Number	304 ESR SS Part Number	Fig. Number	Dimensions		Weight lbs (kg)
				A in. (mm)	B in. (mm)	
Rotatable	F03380000RC4	N/A	3	—	—	2.0 (0.9)
	F03380150RC4	N/A	4	1.51 (38.35)	1.38 (34.93)	1.5 (0.7)
	F03380200RC4	N/A	4	2.02 (51.18)	1.88 (47.63)	1.5 (0.7)

Accessories

Description	Copper Part Number	Silver Plated Copper Part Number	Viton Part Number	Qty/Pkg	Weight lbs (kg)
Gaskets					
10-pack, individually sealed	FG0338CI	FG0338CIS	N/A	10	1.0 (0.5)
1-pack	N/A	N/A	FG0338VU	1	0.5 (0.2)
Gasket clip set	GC0275S	N/A	N/A	10	0.5 (0.2)

Description	Thread/Length	Hex Head Part Number	12-Point Bolt Part Number	Silver Plated 12-Point Bolt Part Number	Qty/Pkg	Weight lbs (kg)
Nut and Bolt Sets						
Clear hole flanges*	5/16-24 x 1 3/4	FB0338C06	FB0338C12	FB0338C12S	25	2.0 (0.9)
Tapped hole flanges**	5/16-24 x 1 1/4	FB0450T06	FB0450T12	FB0450T12S	25	2.0 (0.9)

* Includes nuts, washers, and bolts

** Includes washers and bolts only

NOTE * Custom configurations available on request

ConFlat Flanges

4 1/2 in. (NW63CF) Non-Rotatable

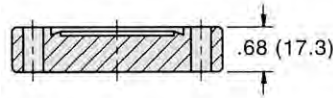

Fig. 1

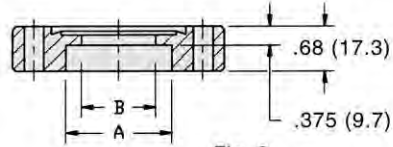

Fig. 2

Thru holes: 8 holes .332 (8.4) dia. thru, eq. spaced on 3.628 (92.2) dia. B.C.
 Tapped holes: 8 holes tapped 5/16-24 thru eq. spaced on 3.628 (92.2) dia. B.C.

Dimensions: inches (millimeters)

Ordering Information

Type	304L SS Part Number	304 ESR SS Part Number	Fig. Number	Dimensions		Weight lbs (kg)
				A in. (mm)	B in. (mm)	
Non-Rotatable	F04500000NC4	F04500000NCE	1	—	—	3.0 (1.4)
	F04500150NC4	F04500150NCE	2	1.51 (38.35)	1.38 (34.93)	2.5 (1.1)
	F04500200NC4	F04500200NCE	2	2.01 (51.05)	1.88 (47.63)	2.5 (1.1)
	F04500250NC4	F04500250NCE	2	2.51 (63.75)	2.38 (60.33)	2.5 (1.1)
Non-Rotatable Tapped	F04500000NT4	F04500000NTE	1	—	—	3.0 (1.4)
	F04500150NT4	N/A	2	1.51 (38.35)	1.38 (34.93)	2.5 (1.1)
	F04500200NT4	N/A	2	2.01 (51.05)	1.88 (47.63)	2.5 (1.1)
	F04500250NT4	N/A	2	2.51 (63.75)	2.38 (60.33)	2.5 (1.1)

Components

4 1/2 in. (NW63CF) Rotatable

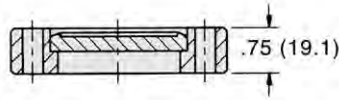

Fig. 3

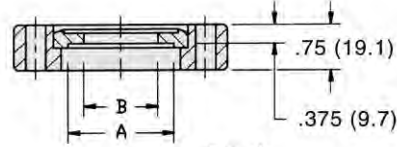

Fig. 4

Thru holes: 8 holes .332 (8.4) dia. thru, eq. spaced on 3.628 (92.2) dia. B.C.
Tapped holes: 8 holes tapped 5/16-24 thru eq. spaced on 3.628 (92.2) dia. B.C.

Dimensions: inches (millimeters)

Ordering Information

Type	304L SS Part Number	304 ESR SS Part Number	Fig. Number	Dimensions		Weight lbs (kg)
				A in. (mm)	B in. (mm)	
Rotatable	F04500000RC4	F04500000RCE	3	—	—	3.0 (1.4)
	F04500150RC4	N/A	4	1.51 (38.35)	1.38 (34.93)	2.5 (1.1)
	F04500200RC4	N/A	4	2.01 (51.05)	1.88 (47.63)	2.5 (1.1)
	F04500250RC4	N/A	4	2.51 (63.75)	2.38 (60.33)	2.5 (1.1)

Accessories

Description	Copper Part Number	Silver Plated Copper Part Number	Viton Part Number	Qty/Pkg	Weight lbs (kg)
Gaskets					
10-pack, individually sealed	FG0450CI	FG0450CIS	N/A	10	2.0 (0.9)
1-pack	N/A	N/A	FG0450VU	1	0.5 (0.2)
Gasket clip set	GC0275S	N/A	N/A	10	0.5 (0.2)

Description	Thread/Length	Hex Head Part Number	12-Point Bolt Part Number	Silver Plated 12-Point Bolt Part Number	Qty/Pkg	Weight lbs (kg)
Nut and Bolt Sets						
Clear hole flanges*	5/16-24 x 2	FB0450C06	FB0450C12	FB0450C12S	25	1.5 (0.7)
Tapped hole flanges**	5/16-24 x 1 1/4	FB0450T06	FB0450T12	FB0450T12S	25	1.5 (0.7)

* Includes nuts, washers, and bolts

** Includes washers and bolts only

NOTE * Custom configurations available on request

ConFlat Flanges

6 in. (NW100CF) Non-Rotatable

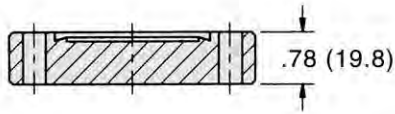

Fig. 1

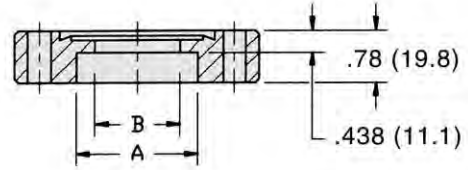

Fig. 2

Thru holes: 16 holes .332 (8.4) dia. thru, eq. spaced on 5.128 (130.3) dia. B.C.
 Tapped holes: 16 holes tapped 5/16-24 thru, eq. spaced on 5.128 (130.3) dia. B.C.

Dimensions: inches (millimeters)

Ordering Information

Type	304L SS Part Number	304 ESR SS Part Number	Fig. Number	Dimensions		Weight lbs (kg)
				A in. (mm)	B in. (mm)	
Non-Rotatable	F06000000NC4	F06000000NCE	1	—	—	6.5 (2.9)
	F06000400NC4	F06000400NCE	2	4.01 (101.85)	3.81 (96.77)	4.5 (2.0)
Non-Rotatable	F06000000NT4	N/A	1	—	—	6.5 (2.9)
Tapped	F06000400NT4	F06000400NTE	2	4.01 (101.85)	3.81 (96.77)	4.5 (2.0)

6 in. (NW100CF) Rotatable

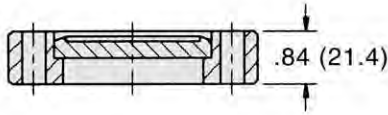

Fig. 3

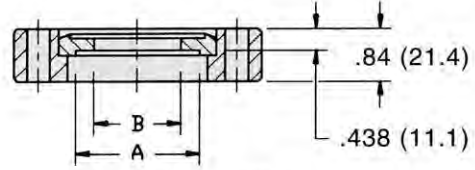

Fig. 4

Thru holes: 16 holes .332 (8.4) dia. thru, eq. spaced on 5.128 (130.3) dia. B.C.
Tapped holes: 16 holes tapped 5/16-24 thru, eq. spaced on 5.128 (130.3) dia. B.C.

Dimensions: inches (millimeters)

Ordering Information

Type	304L SS		Fig. Number	Dimensions		Weight lbs (kg)
	Part Number	304 ESR SS Part Number		A in. (mm)	B in. (mm)	
Rotatable	F06000000RC4	F06000000RCE	3	—	—	6.5 (2.9)
	F06000400RC4	N/A	4	4.01 (101.85)	3.81 (96.77)	4.5 (2.0)

NOTE • 316LN SS material available on request.
• Custom configurations available on request

Accessories

Description	Copper Part Number	Silver Plated Copper Part Number	Viton Part Number	Qty/Pkg	Weight lbs (kg)
Gaskets					
10-pack, individually sealed	FG0600CI	FG0600CIS	N/A	10	1.5 (0.7)
1-pack	N/A	N/A	FG0600VU	1	1.0 (0.5)
Gasket clip set	GC0275S	N/A	N/A	10	.5 (0.2)

Description	Thread/Length	Hex Head Part Number	12-Point Bolt Part Number	Silver Plated 12-Point Bolt Part Number	Qty/Pkg	Weight lbs (kg)
Nut and Bolt Sets						
Clear hole flanges						
Non-rotatable*	5/16-24 x 2	FB0450C06	FB0450C12	FB0450C12S	25	2.0 (0.9)
Clear hole flanges						
Rotatable*	5/16-24 x 2 1/4	FB0600C06	FB0600C12	FB0600C12S	25	2.0 (0.9)
Tapped hole flanges**	5/16-24 x 1 1/4	FB0450T06	FB0450T12	FB0450T12S	25	1.5 (0.7)

* Includes nuts, washers, and bolts

** Includes washers and bolts only

NOTE • Custom configurations available on request

ConFlat Flanges

6 3/4 in. (NW130CF) Non-Rotatable

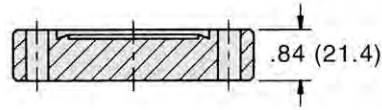

Fig. 1

Thru holes: 18 holes .332 (8.4) dia. thru, eq. spaced on 5.969 (151.6) dia. B.C.

Tapped holes: 18 holes tapped 5/16-24 thru, eq. spaced on 5.969 (151.6) dia. B.C.

Dimensions: inches (millimeters)

Ordering Information

Type	304L SS Part Number	304 ESR SS Part Number	Fig. Number	Dimensions		Weight lbs (kg)
				A in. (mm)	B in. (mm)	
Non-Rotatable	F06750000NC4	F06750000NCE	1	–	–	8.0 (3.6)

Components

Accessories

Description	Copper Part Number	Silver Plated Copper Part Number	Viton Part Number	Qty/Pkg	Weight lbs (kg)
Gaskets					
10-Pack, individually sealed	FG0675CI	FG0675CIS	N/A	10	2.0 (0.9)
1-pack	N/A	N/A	FG0675VU	1	1.0 (0.5)
Gasket clip set	GC0275S	N/A	N/A	10	0.5 (0.2)

Description	Thread/Length	Hex Head Part Number	12-Point Bolt Part Number	Silver Plated 12-Point Bolt Part Number	Qty/Pkg	Weight lbs (kg)
Nut and Bolt Sets						
Clear hole flanges*	$\frac{5}{16}$ -24 x 2 $\frac{1}{4}$	FB0600C06	FB0600C12	FB0600C12S	25	2.0 (0.9)
Tapped hole flanges**	$\frac{5}{16}$ -24 x 1 $\frac{3}{4}$	FB0800T06	FB0800T12	FB0800T12S	25	2.0 (0.9)

* Includes nuts, washers, and bolts

** Includes washers and bolts only

NOTE ° Custom configurations available on request

ConFlat Flanges

8 in. (NW150CF) Non-Rotatable

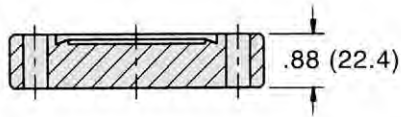

Fig. 1

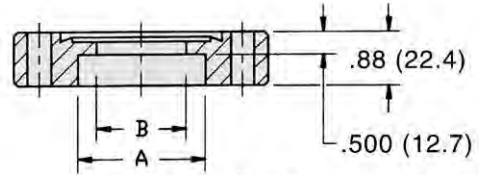

Fig. 2

Thru holes: 20 holes .332 (8.4) dia. thru, eq. spaced on 7.128 (181.1) dia. B.C.
 Tapped holes: 20 holes tapped 5/16-24 thru, eq. spaced on 7.128 (181.1) dia. B.C.

Dimensions: inches (millimeters)

Ordering Information

Type	304L SS Part Number	304 ESR SS Part Number	Fig. Number	Dimensions		Weight lbs (kg)
				A in. (mm)	B in. (mm)	
Non-Rotatable	F08000000NC4	F08000000NCE	1	—	—	12.5 (5.6)
	F08000600NC4	F08000600NCE	2	6.02 (152.91)	5.81 (147.57)	5.8 (2.6)
Non-Rotatable	F08000000NT4	N/A	1	—	—	12.5 (5.6)
Tapped	F08000600NT4	N/A	2	6.02 (152.91)	5.81 (147.57)	5.8 (2.6)

Components

8 in. (NW150CF) Rotatable

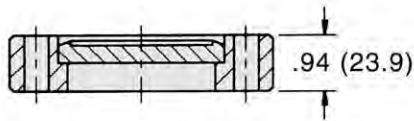

Fig. 3

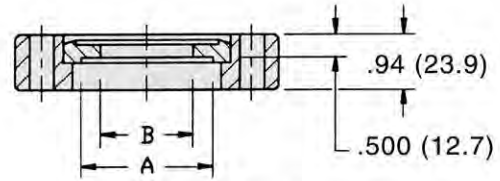

Fig. 4

Thru holes: 20 holes .332 (8.4) dia. thru, eq. spaced on 7.128 (181.1) dia. B.C.
Tapped holes: 20 holes tapped 5/16-24 thru, eq. spaced on 7.128 (181.1) dia. B.C.

Dimensions: inches (millimeters)

Ordering Information

Type	304L SS		Fig. Number	Dimensions		Weight lbs (kg)
	Part Number	Part Number		A in. (mm)	B in. (mm)	
Rotatable	F08000000RC4	F08000000RCE	3	—	—	10.0 (4.5)
	F08000600RC4	F08000600RCE	4	6.02 (152.91)	5.81 (147.57)	7.0 (3.2)

Accessories

Description	Copper Part Number	Silver Plated Copper Part Number	Viton Part Number	Qty/Pkg	Weight lbs (kg)
Gaskets					
10-pack, individually sealed	FG0800CI	FG0800CIS	N/A	10	2.5 (1.1)
1-pack	N/A	N/A	FG0800VU	1	1.0 (0.5)
Gasket clip set	GC0275S	N/A	N/A	10	0.5 (0.2)

Description	Thread/Length	Hex Head Part Number	12-Point Bolt Part Number	Silver Plated 12-Point Bolt Part Number	Qty/Pkg	Weight lbs (kg)
Nut and Bolt Sets						
Clear hole flanges*	5/16-24 x 2 1/4	FB0600C06	FB0600C12	FB0600C12S	25	2.0 (0.9)

* Includes nuts, washers, and bolts

** Includes washers and bolts only

NOTE ° Custom configurations available on request

ConFlat Flanges

10 in. (NW200CF) Non-Rotatable

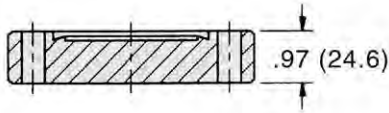

Fig. 1

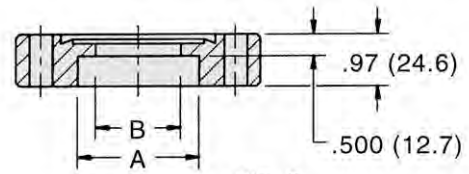

Fig. 2

Thru holes: 24 holes .332 (8.4) dia. thru, eq. spaced on 9.128 (231.9) dia. B.C.

Tapped holes: 24 holes tapped 5/16-24 thru, eq. spaced on 9.128 (231.9) dia. B.C.

Dimensions: inches (millimeters)

Ordering Information

Type	304L SS Part Number	304 ESR SS Part Number	Fig. Number	Dimensions		Weight lbs (kg)
				A in. (mm)	B in. (mm)	
Non-Rotatable	F10000000NC4	F10000000NCE	1	—	—	21.0 (9.5)
	F10000800NC4	F10000800NCE	2	8.04 (204.22)	7.81 (198.37)	8.0 (3.6)
Non-Rotatable	F10000000NT4	N/A	1	—	—	21.0 (9.5)
Tapped	F10000800NT4	N/A	2	8.04 (204.22)	7.81 (198.37)	8.0 (3.6)

Components

10 in. (NW200CF) Rotatable

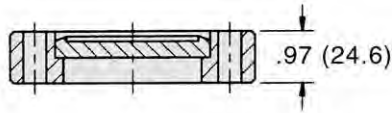

Fig. 3

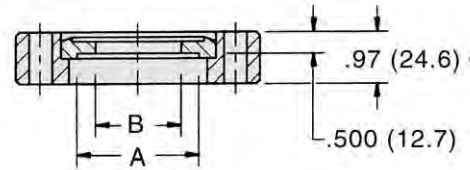

Fig. 4

Thru holes: 24 holes .332 (8.4) dia. thru, eq. spaced on 9.128 (231.9) dia. B.C.
 Tapped holes: 24 holes tapped 5/16-24 thru, eq. spaced on 9.128 (231.9) dia. B.C.

Dimensions: inches (millimeters)

Ordering Information

Type	304L SS Part Number	304 ESR SS Part Number	Fig. Number	Dimensions		Weight lbs (kg)
				A in. (mm)	B in. (mm)	
Rotatable	F10000000RC4	F10000000RCE	3	—	—	15.0 (6.8)
	F10000800RC4	F10000800RCE	4	8.02 (203.71)	7.81 (198.37)	12.0 (5.4)

Accessories

Description	Copper Part Number	Silver Plated Copper Part Number	Viton Part Number	Qty/Pkg	Weight lbs (kg)
Gaskets					
10-pack, individually sealed	FG1000CI	FG1000CIS	N/A	10	3.0 (1.3)
1-pack	N/A	N/A	FG1000VU	1	1.0 (0.5)
Gasket clip set	GC0275S	N/A	N/A	10	0.5 (0.2)

Description	Thread/Length	Hex Head Part Number	12-Point Bolt Part Number	Silver Plated 12-Point Bolt Part Number	Qty/Pkg	Weight lbs (kg)
Nut and Bolt Sets						
Clear hole flanges*	5/16-24 x 2 1/2	FB1000C06	FB1000C12	FB1000C12S	25	2.0 (0.9)
Tapped hole flanges**	5/16-24 x 1 3/4	FB0800T06	FB0800T12	FB0800T12S	25	1.5 (0.7)

* Includes nuts, washers, and bolts

** Includes washers and bolts only

NOTE * Custom configurations available on request

ConFlat Flanges

13 1/4 in. (NW275CF) Non-Rotatable

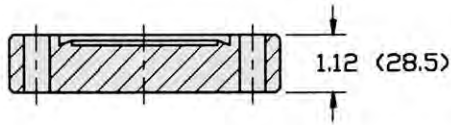

FIG. 1

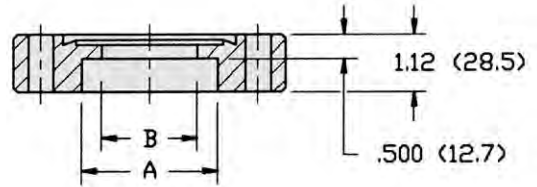

FIG. 2

THRU HOLES: 30 HOLES .390 (9.9) DIA. THRU, EQ. SPACED ON 12.060 (306.3) DIA. B.C.
 TAPPED HOLES: 30 HOLES TAPPED 3/8-24 THRU, EQ. SPACED ON 12.060 (306.3) DIA. B.C.

Dimensions: inches (millimeters)

Ordering Information

Type	304L SS Part Number	304 ESR SS Part Number	Fig. Number	Dimensions		Weight lbs (kg)
				A in. (mm)	B in. (mm)	
Non-Rotatable	F13250000NC4	F13250000NCE	1	—	—	41.0 (18.6)
	F13251000NC4	F13251000NCE	2	10.03 (254.76)	9.86 (250.44)	18.0 (8.2)
	F13251075NC4	F13251075NCE	2	10.77 (273.43)	10.63 (270.00)	14.0 (6.4)

13 1/4 in. (NW275CF) Rotatable

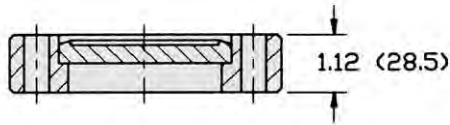

FIG. 3

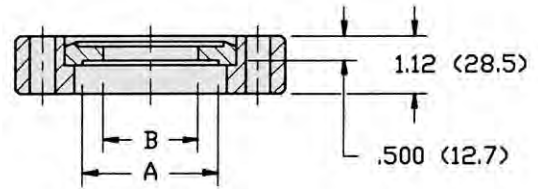

FIG. 4

THRU HOLES: 30 HOLES .390 (9.9) DIA. THRU, EQ. SPACED ON 12.060 (306.3) DIA. B.C.
 TAPPED HOLES: 30 HOLES TAPPED 3/8-24 THRU, EQ. SPACED ON 12.060 (306.3) DIA. B.C.

Dimensions: inches (millimeters)

Ordering Information

Type	304L SS Part Number	304 ESR SS Part Number	Fig. Number	Dimensions		Weight lbs (kg)
				A in. (mm)	B in. (mm)	
Rotatable	N/A	F1325000RCE	3	—	—	41.0 (18.6)
	N/A	F13251000RCE	4	10.03 (254.76)	9.86 (250.44)	18.0 (8.2)
	N/A	F13251075RCE	4	10.77 (273.43)	10.63 (270.00)	14.0 (6.4)

NOTE • Custom configurations available on request

Accessories

Description	Copper Part Number	Viton Part Number	Qty/Pkg	Weight lbs (kg)
Gaskets				
1-pack, individually sealed	FG1325CI	N/A	1	0.5 (0.2)
1-pack	N/A	FG1325VU	1	0.5 (0.2)
Gasket clip set	GC0275S	N/A	10	0.5 (0.2)

Description	Thread/Length	Hex Head Part Number	12-Point Bolt Part Number	Qty/Pkg	Weight lbs (kg)
Nut and Bolt Sets					
Clear hole flanges*	3/8-24 x 3	FB1325C06	N/A	30	2.0 (0.9)
Tapped hole flanges**	3/8-24 x 2	FB1325T06	N/A	30	2.0 (0.9)

* Includes nuts, washers, and bolts

** Includes washers and bolts only

ConFlat Flanges

2¾ in. - 10 in. Reducing

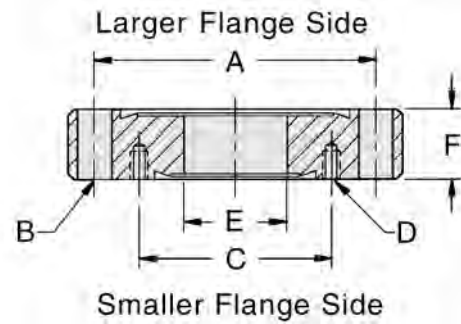

Ordering Information

Size	304L SS Part Number	304 ESR SS Part Number	Larger Flange Dimensions		
			Bolt Circle A in. (mm)	# of Holes	Hole Diam. B in. (mm)
2¾ in.	N/A	FR02750133E	2.31 (58.72)	6	0.27 (6.73)
4½ in.	N/A	FR04500133E	3.63 (92.15)	8	0.33 (8.43)
	N/A	FR04500275E	3.63 (92.15)	8	0.33 (8.43)
6 in.	FR060001334	FR06000133E	5.13 (130.25)	16	0.33 (8.43)
	FR060002124	N/A	5.13 (130.25)	16	0.33 (8.43)
	FR060002754	FR06000275E	5.13 (130.25)	16	0.33 (8.43)
	FR060003384	N/A	5.13 (130.25)	16	0.33 (8.43)
	FR060004504	FR06000450E	5.13 (130.25)	16	0.33 (8.43)
8 in.	FR080001334	N/A	7.13 (181.05)	20	0.33 (8.43)
	FR080002754	FR08000275E	7.13 (181.05)	20	0.33 (8.43)
	FR080003384	N/A	7.13 (181.05)	20	0.33 (8.43)
	FR080004504	FR08000450E	7.13 (181.05)	20	0.33 (8.43)
	FR080006004	FR08000600E	7.13 (181.05)	20	0.33 (8.43)
	FR080006754T*	N/A	7.13 (181.05)	20	($\sqrt[5]{16-24}$)
10 in.	FR100001334	N/A	9.13 (231.85)	24	0.33 (8.43)
	FR100002754	N/A	9.13 (231.85)	24	0.33 (8.43)
	FR100003384	N/A	9.13 (231.85)	24	0.33 (8.43)
	FR100004504	N/A	9.13 (231.85)	24	0.33 (8.43)
	FR100006004	N/A	9.13 (231.85)	24	0.33 (8.43)
	FR100008004	N/A	9.13 (231.85)	24	0.33 (8.43)

* Both sets of bolt holes are tapped.

Components

Bolt Circle C in. (mm)	Smaller Flange Dimensions		ID E in. (mm)	Thickness F in. (mm)	Weight lbs (kg)
	# of Holes	Thread D			
1.06 (27.00)	6	8-32	0.62 (15.75)	0.50 (12.70)	0.8 (0.3)
1.06 (26.98)	6	8-32	0.62 (15.75)	0.68 (17.27)	3.0 (1.4)
2.31 (58.73)	6	¼-28	1.50 (38.10)	0.68 (17.27)	2.5 (1.1)
1.06 (26.98)	6	8-32	0.62 (15.75)	0.78 (19.81)	6.0 (2.7)
1.63 (41.40)	4	¼-28	1.00 (25.40)	0.78 (19.81)	5.5 (2.5)
2.31 (58.73)	6	¼-28	1.50 (38.10)	0.78 (19.81)	5.5 (2.5)
2.85 (72.39)	8	⅝-24	1.88 (47.63)	0.78 (19.81)	5.0 (2.3)
3.63 (92.15)	8	⅝-24	2.50 (63.50)	0.78 (19.81)	4.5 (2.0)
1.06 (26.98)	6	8-32	0.62 (15.75)	0.88 (22.35)	12.0 (5.4)
2.31 (58.73)	6	¼-28	1.50 (38.10)	0.88 (22.35)	12.0 (5.4)
2.85 (72.39)	8	⅝-24	2.00 (50.80)	0.88 (22.35)	11.0 (5.0)
3.63 (92.15)	8	⅝-24	2.50 (63.50)	0.88 (22.35)	11.0 (5.0)
5.13 (130.25)	16	⅝-24	4.00 (101.60)	0.88 (22.35)	10.0 (4.5)
5.97 (151.61)	18	⅝-24	5.00 (127.00)	0.88 (22.35)	10.0 (4.5)
1.06 (26.98)	6	8-32	0.62 (15.75)	0.97 (24.64)	20.0 (9.0)
2.31 (58.73)	6	¼-28	1.50 (38.10)	0.97 (24.64)	20.0 (9.0)
2.85 (72.40)	8	⅝-24	2.00 (50.80)	0.97 (24.64)	20.0 (9.0)
3.63 (92.11)	8	⅝-24	2.50 (63.50)	0.97 (24.64)	20.0 (9.0)
5.13 (130.25)	16	⅝-24	4.00 (101.60)	0.97 (24.64)	17.0 (7.7)
7.13 (181.05)	20	⅝-24	6.00 (152.40)	0.97 (24.64)	17.0 (7.7)

ConFlat Flanges

Accessories

Accessories – Gaskets

Size	Gasket Material	Description	Part Number	Qty/Pkg	Weight lbs (kg)
1 1/8 in.	Copper	Individually sealed	FG0133CI	10	1.0 (0.5)
	Viton	Packaged together	FG0133VU	5	0.5 (0.2)
	Silver plated copper	Packaged together	FG0133CIS	10	1.0 (0.5)
		Clip set	GC0275S	10	1.0 (0.5)
2 1/8 in.	Copper	Individually sealed	FG0212CI	10	1.0 (0.5)
	Viton	Packaged together	FG0212VU	5	0.5 (0.2)
	Silver plated copper	Individually sealed	FG0212CIS	10	1.0 (0.5)
		Clip set	GC0275S	10	0.5 (0.2)
2 3/4 in.	Copper	Individually sealed	FG0275CI	10	1.0 (0.5)
	Viton	Packaged together	FG0275VU	5	0.5 (0.2)
	Silver plated copper	Packaged together	FG0275CIS	10	1.0 (0.5)
		Clip set	GC0275S	10	1.0 (0.5)
3 3/8 in.	Copper	Individually sealed	FG0338CI	10	1.0 (0.5)
	Viton	Individually sealed	FG0338VU	1	0.5 (0.2)
	Silver plated copper	Packaged together	FG0338CIS	10	1.0 (0.5)
		Clip set	GC0275S	10	1.0 (0.5)
4 1/2 in.	Copper	Individually sealed	FG0450CI	10	1.0 (0.5)
	Viton	Individually sealed	FG0450VU	1	0.5 (0.2)
	Silver plated copper	Packaged together	FG0450CIS	10	1.0 (0.5)
		Clip set	GC0275S	10	1.0 (0.5)
4 7/8 in.	Copper	Individually sealed	FG0462CI	10	1.0 (0.5)
	Viton	Individually sealed	FG0462VU	1	0.5 (0.2)
	Silver plated copper	Individually sealed	FG0462CIS	10	2.0 (0.9)
		Clip set	GC0275S	10	0.5 (0.2)
6 in.	Copper	Individually sealed	FG0600CI	10	2.0 (0.9)
	Viton	Individually sealed	FG0600VU	1	0.5 (0.2)
	Silver plated copper	Packaged together	FG0600CIS	10	2.0 (0.9)
		Clip set	GC0275S	10	1.0 (0.5)
6 3/4 in.	Copper	Individually sealed	FG0675CI	10	2.0 (0.9)
	Viton	Individually sealed	FG0675VU	1	0.5 (0.2)
	Silver plated copper	Packaged together	FG0675CIS	10	2.0 (0.9)
		Clip set	GC0275S	10	1.0 (0.5)
8 in.	Copper	Individually sealed	FG0800CI	10	2.0 (0.9)
	Viton	Individually sealed	FG0800VU	1	0.5 (0.2)
	Silver plated copper	Packaged together	FG0800CIS	10	2.0 (0.9)
		Clip set	GC0275S	10	1.0 (0.5)
10 in.	Copper	Individually sealed	FG1000CI	10	2.5 (1.1)
	Viton	Individually sealed	FG1000VU	1	0.5 (0.2)
	Silver plated copper	Packaged together	FG1000CIS	10	2.5 (1.1)
		Clip set	GC0275S	10	1.0 (0.5)
12 in.	Copper	Individually sealed	FG1200CI	1	2.5 (1.1)
	Viton	Individually sealed	FG1200VU	1	0.5 (0.2)
	Silver plated copper	Individually sealed	FG1200CIS	1	2.0 (0.9)
		Clip set	GC0275S	10	0.5 (0.2)
13 1/4 in.	Copper	Individually sealed	FG1325CI	1	3.5 (1.6)
	Viton	Individually sealed	FG1325VU	1	0.5 (0.2)

Recommended Torque Specifications for Tightening ConFlat Bolts

Flange Size	Size/Thread	Torque – inch lbs
For ConFlats 1 1/8 in.	(8-32)	51
For ConFlats 2 1/8 in. and 2 3/4 in.	(1/4-28)	96
For ConFlats 3 3/8 in. to 12 in.	(5/16-24)	192
For ConFlats 13 1/4 in.	(3/8-24)	345

VacuumXpress

Accessories – Bolt Sets for Double-Sided Flanges

Size	Nut and Bolt Sets	Thread/Length	Hex Head Part Number	12-Point Bolt Part Number	Qty/Pkg	Shipping Weight lbs (kg)
2 ¼ in.	Clear hole flanges*	¼-28 x 2 ¼	FB0275CD06	FB0275CD12	6	1.0 (0.5)
3 ⅝ in.	Clear hole flanges*	⅝-24 x 2 ¼	FB0338CD06	N/A	8	2.0 (0.9)
4 ½ in.	Clear hole flanges*	⅝-24 x 2 ½	FB0450CD06	FB0450CD12	10	1.0 (0.5)
4 ⅞ in.	Clear hole flanges*	⅝-24 x 2 ¾	FB0462CD06	N/A	10	2.0 (0.9)
6 in.	Clear hole flanges*	⅝-24 x 2 ¾	FB0600CD06	N/A	16	2.0 (0.9)
6 ¾ in.	Clear hole flanges*	⅝-24 x 3	FB0675CD06	FB0675CD12	18	2.5 (1.1)
8 in.	Clear hole flanges*	⅝-24 x 3 ¼	FB0800CD06	N/A	20	3.0 (1.4)
10 in.	Clear hole flanges*	⅝-24 x 3 ½	FB1000CD06	N/A	24	3.5 (1.6)
13 ¼ in.	Clear hole flanges*	⅝-24 x 4	FB1325CD06	N/A	30	4.0 (1.8)

*Includes nuts, washers, and bolts

**Only available in socket head

Accessories – Bolt Sets for CF to KF Adapters

Size	Nut and Bolt Sets	Hex Head Part Number	12-Point Bolt Part Number	Qty/Pkg	Shipping Weight lbs (kg)
1 ⅓ in.	Clear hole flanges	N/A	FB0133C**	25	0.5 (0.2)
	Tapped hole flanges	N/A	FB0133T**	25	0.5 (0.2)
2 ⅞ in.	Clear hole flanges	FB0275C06	FB0275C12	25	1.0 (0.5)
	Tapped hole flanges	FB0275T06	FB0275T12	25	1.0 (0.5)
2 ¾ in.	Clear hole flanges	FB0275C06	FB0275C12	25	1.0 (0.5)
	Tapped hole flanges	FB0275T06	FB0275T12	25	1.0 (0.5)
3 ⅝ in.	Clear hole flanges	FB0338C06	FB0338C12	25	2.0 (0.9)
	Tapped hole flanges	FB0450T06	FB0450T12	25	2.0 (0.9)
4 ½ in.	Clear hole flanges	FB0450C06	FB0450C12	25	2.0 (0.9)
	Tapped hole flanges	FB0450T06	FB0450T12	25	2.0 (0.9)
4 ⅝ in.	Clear hole flanges non rot.	FB0450C06	FB0450C12	25	1.5 (0.7)
	Clear hole flanges rot.	FB0600C06	FB0600C12	25	1.5 (0.7)
	Tapped hole flanges	FB0450T06	FB0450T12	25	1.5 (0.7)

*Includes nuts, washers, and bolts

**Only available in socket head

Accessories – Bolt Sets for Reducing Flanges

Flange Size	Part Number	Small Flange	Large Flange	Weight lbs (kg)
2 ¾ in. to 1 ⅓ in.	FB02750133CR12	6 bolts/washers	6 bolts/washers	2.0 (0.9)
3 ⅝ in. to 1 ⅓ in.	FB03380133CR12	6 bolts/washers	8 bolts/washers/nuts	3.0 (1.4)
3 ⅝ in. to 2 ¾ in.	FB03380275CR12	6 bolts	8 bolts	3.0 (1.4)
4 ½ in. to 2 ¾ in.	FB04500275CR12	6 bolts/washers	8 bolts/washers/nuts	3.0 (1.4)
4 ½ in. to 3 ⅝ in.	FB04500338CR12	8 bolts	8 bolts	3.0 (1.4)
6 in. to 2 ¾ in.	FB06000275CR12	6 bolts/washers	16 bolts/washers/nuts	4.0 (1.8)
6 in. to 3 ⅝ in.	FB06000338CR12	8 bolts/washers	16 bolts/washers/nuts	4.0 (1.8)
6 in. to 4 ½ in.	FB06000450CR12	8 bolts/washers	16 bolts/washers/nuts	4.0 (1.8)
8 in. to 2 ¾ in.	FB08000275CR12	6 bolts/washers	20 bolts/washers/nuts	4.0 (1.8)
8 in. to 4 ½ in.	FB08000450CR12	8 bolts/washers	20 bolts/washers/nuts	4.0 (1.8)
8 in. to 6 in.	FB08000600CR12	16 bolts/washers	20 bolts/washers/nuts	4.0 (1.8)
10 in. to 2 ¾ in.	FB10000275CR12	6 bolts/washers	24 bolts/washers/nuts	5.0 (2.3)
10 in. to 6 in.	FB10000600CR12	16 bolts/washers	24 bolts/washers/nuts	5.0 (2.3)
10 in. to 8 in.	FB10000800CR12	20 bolts/washers	24 bolts/washers/nuts	5.0 (2.3)

NOTE • Reducing flange bolt sets include sockets, 6 point and 12 point bolts dependent on size:

1.33 bolts are socket keyed (SH), 6.75 in. and 13.25 in. bolts are hex head.

All other sizes are 12 point heads.

ConFlat Fittings

Reducing Nipples - 304 Stainless Steel

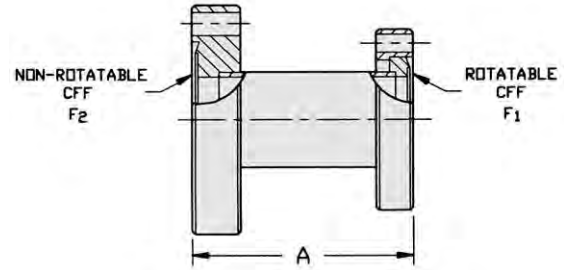
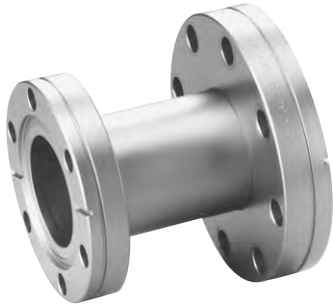

Ordering Information

Flange Size	Part Number	Length A in. (mm)	Non-Rotatable F2	Rotatable F1	Shipping Weight lbs (kg)
2 3/4 in.	FA02750133	2.50 (63.50)	2 3/4	1 1/2	1.5 (0.7)
	FA02750212	2.75 (69.85)	2 3/4	2 1/8	1.5 (0.7)
4 1/2 in.	FA04500133	2.50 (63.50)	4 1/2	1 1/2	4.0 (1.8)
	FA04500275	2.50 (63.50)	4 1/2	2 3/4	4.0 (1.8)
	FA04500275L	3.00 (76.20)	4 1/2	2 3/4	4.0 (1.8)
6 in.	FA06000133	2.50 (63.50)	6	1 1/2	8.0 (3.6)
	FA06000275	3.25 (82.55)	6	2 3/4	8.0 (3.6)
	FA06000450	2.50 (63.50)	6	4 1/2	10.0 (4.5)
	FA06000450L	4.25 (107.95)	6	4 1/2	12.0 (5.4)
8 in.	FA08000275	2.50 (63.50)	8	2 3/4	14.0 (6.3)
	FA08000275L	4.00 (101.60)	8	2 3/4	14.0 (6.3)
	FA08000450	2.50 (63.50)	8	4 1/2	16.0 (7.2)
	FA08000600	2.50 (63.50)	8	6	18.0 (8.1)
	FA08000600L	4.50 (114.30)	8	6	16.0 (7.2)
10 in.	FA10000275	3.50 (88.90)	10	2 3/4	25.0 (11.3)
	FA10000800	4.75 (120.65)	10	8	20.0 (9.0)

NOTE • Custom lengths/configurations available on request
 • Clear Hole ConFlat Flange

Half Nipples

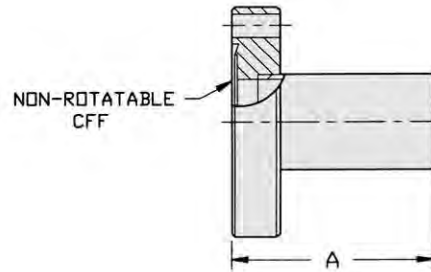

Ordering Information – Half Nipples, Standard Tube Size

Tube Size	Part Number	Flange OD	Overall Length A in. (mm)	Tube OD in. (mm)	Tube ID in. (mm)	Shipping Weight lbs (kg)
¾ in.	FNH0075	1 ½ in.	1.50 (38.10)	0.75 (19.05)	0.68 (17.27)	0.8 (0.3)
1 in.	FNH0100275	2 ¾ in.	2.46 (62.48)	1.00 (25.40)	0.87 (19.81)	1.0 (0.5)
1 ½ in.	FNH0150S	2 ¾ in.	2.46 (62.48)	1.50 (38.10)	1.37 (34.80)	1.0 (0.5)
	FNH0150	2 ¾ in.	4.71 (119.63)	1.50 (38.10)	1.37 (34.80)	1.0 (0.5)
2 in.	FNH0200	3 ¾ in.	3.21 (81.53)	2.00 (50.80)	1.87 (47.50)	2.0 (0.9)
2 ½ in.	FNH0250S	4 ½ in.	3.38 (85.85)	2.50 (63.50)	2.37 (60.20)	6.0 (2.7)
	FNH0250	4 ½ in.	4.12 (104.65)	2.50 (63.50)	2.37 (60.20)	6.0 (2.7)
3 in.	FNH0300S	4 ¾ in.	3.53 (89.66)	3.00 (76.20)	2.87 (72.90)	7.0 (3.2)
4 in.	FNH0400S	6	4.32 (109.73)	4.00 (101.60)	3.83 (97.28)	11.0 (4.9)
	FNH0400	6	5.31 (134.87)	4.00 (101.60)	3.83 (97.28)	11.0 (4.9)
6 in.	FNH0600S	8	5.50 (139.70)	6.00 (152.40)	5.83 (148.08)	19.0 (8.6)
	FNH0600	8	6.56 (166.62)	6.00 (152.40)	5.83 (148.08)	19.0 (8.6)
8 in.	FNH0800	10	8.00 (203.20)	8.00 (203.20)	7.83 (198.88)	26.0 (11.8)

Ordering Information – Half Nipples, Rotatable Flanges

Tube Size	Part Number	Flange OD	Overall Length A in. (mm)	Tube OD in. (mm)	Tube ID in. (mm)	Shipping Weight lbs (kg)
1 ½ in.	FNH0150R	2 ¾ in.	2.36 (60.00)	1.50 (38.10)	1.37 (34.80)	1.0 (0.5)
2 ½ in.	FNH0250R	4 ½ in.	3.15 (80.01)	2.50 (63.50)	2.33 (59.18)	6.0 (2.7)
4 in.	FNH0400R	6	3.54 (89.92)	4.00 (101.60)	3.83 (97.28)	11.0 (4.9)

NOTE * Custom configurations available on request
 * Clear Hole ConFlat Flange

ConFlat Fittings

Nipples

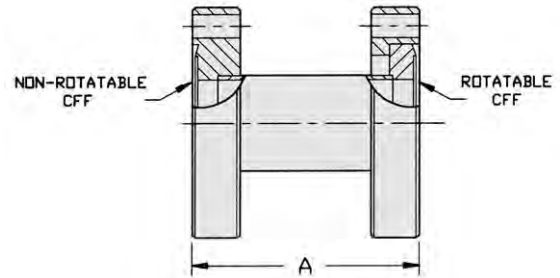

Ordering Information

Tube Size	Part Number	Flange OD	Overall Length A in. (mm)	Tube OD in. (mm)	Tube ID in. (mm)	Shipping Weight lbs (kg)
¾ in.	FNF0075	1 ½	3.00 (76.20)	0.75 (19.05)	0.62 (17.27)	1.5 (0.7)
1 ½ in.	FNF0150	2 ¾	4.93 (125.22)	1.50 (38.10)	1.37 (34.80)	2.0 (0.9)
2 in.	FNF0200	3 ⅞	6.43 (163.32)	2.00 (50.80)	1.87 (47.50)	4.0 (1.8)
2 ½ in.	FNF0250	4 ½	8.25 (209.55)	2.50 (63.50)	2.37 (60.20)	8.0 (3.6)
	FNF0250S	4 ½	6.76 (171.70)	2.50 (63.50)	2.37 (60.20)	8.0 (3.6)
4 in.	FNF0400	6	10.63 (270.00)	4.00 (101.60)	3.83 (97.28)	15.0 (6.8)
	FNF0400S	6	8.64 (219.46)	4.00 (101.60)	3.83 (97.28)	13.0 (5.9)
6 in.	FNF0600	8	13.13 (333.50)	6.00 (152.40)	5.83 (148.08)	24.0 (10.8)
	FNF0600S	8	11.00 (279.40)	6.00 (152.40)	5.83 (148.08)	24.0 (10.8)
8 in.	FNF0800	10	16.00 (406.40)	8.00 (203.20)	7.83 (198.88)	30.0 (13.5)
	FNF0800S	10	15.00 (381.00)	8.00 (203.20)	7.83 (198.88)	30.0 (13.5)

NOTE • Custom configurations available on request
 • Clear Hole ConFlat Flange

Components

Elbows (90°)

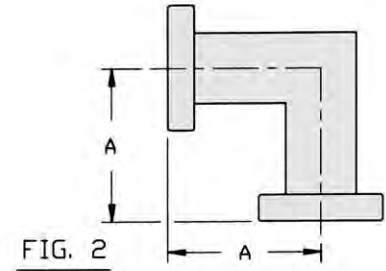
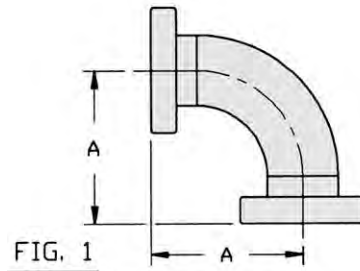

Ordering Information

Nominal Tube Size	Part Number	Flange Size	Fig. Number	Dimension A in. (mm)	Shipping Weight lbs (kg)
¾ in.	FE0075	1½	1	1.50 (38.10)	1.5 (0.7)
1½ in.	FE0150	2¾	1	2.46 (62.48)	2.0 (0.9)
2 in.	FE0200	3¾	2	3.21 (81.53)	4.0 (1.8)
2½ in.	FE0250	4½	2	4.13 (104.90)	8.0 (3.6)
4 in.	FE0400	6	2	5.31 (134.87)	15.0 (6.8)
6 in.	FE0600	8	2	6.56 (166.62)	24.0 (10.8)

NOTE • Custom configurations available on request
 • All flanges are rotatable
 • Clear Hole ConFlat Flange

ConFlat Fittings

Tees

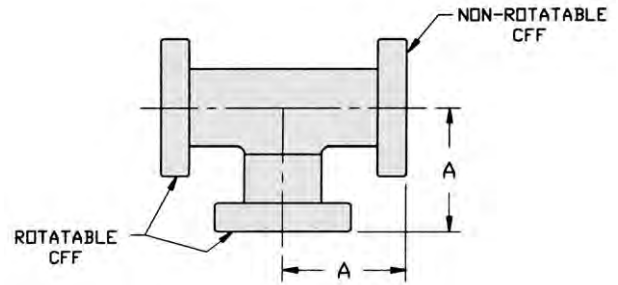

Ordering Information

Nominal Tube Size	Part Number	Flange Size	Dimension A in. (mm)	Shipping Weight lbs (kg)
¾ in.	FT0075	1 ⅓	1.50 (38.10)	2.0 (0.9)
1 ½ in.	FT0150	2 ¾	2.46 (62.50)	4.0 (1.8)
2 in.	FT0200	3 ⅞	3.21 (81.53)	8.0 (3.6)
2 ½ in.	FT0250	4 ½	4.13 (104.90)	11.0 (4.9)
4 in.	FT0400	6	5.31 (134.87)	21.0 (9.5)
6 in.	FT0600	8	6.56 (166.62)	34.0 (15.4)

NOTE • Custom configurations available on request
 • Clear Hole ConFlat Flange

Crosses (4-Way)

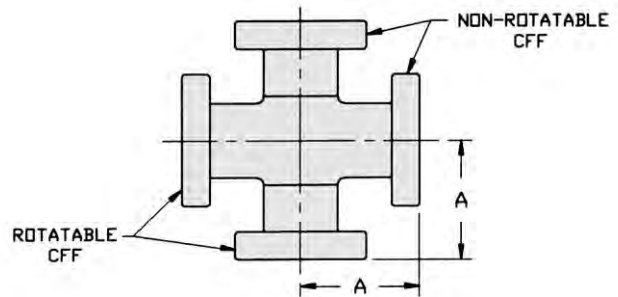
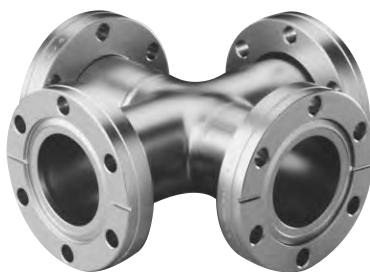

Ordering Information

Nominal Tube Size	Part Number	Flange Size	Dimension A in. (mm)	Shipping Weight lbs (kg)
¾ in.	FC0075	1 ⅓	1.50 (38.10)	2.3 (1.0)
1 ½ in.	FC0150	2 ¾	2.46 (62.50)	4.0 (1.8)
2 in.	FC0200	3 ⅞	3.21 (81.53)	9.0 (4.1)
2 ½ in.	FC0250	4 ½	4.13 (104.90)	14.0 (6.3)
4 in.	FC0400	6	5.31 (134.87)	26.0 (11.8)
6 in.	FC0600	8	6.56 (166.62)	44.0 (19.9)

NOTE • Custom configurations available on request
 • Clear Hole ConFlat Flange

Flexible Couplings (Non-Braided)

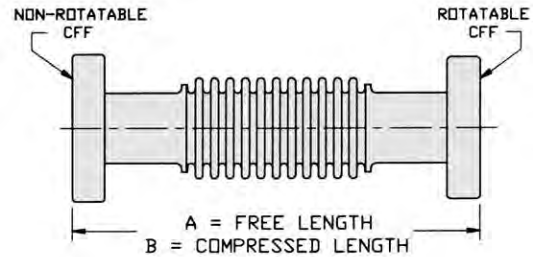

Specifications

- Vacuum-compatible stainless steel
- Sizes ¼ in. – 6 in.
- Full penetration vacuum welds

Ordering Information

Nominal O.D.	Part Number	Flange Size	Length Free A in. (mm)	Length Compressed B in. (mm)	Static Bend Radius in. (mm)	Bellows Wall Thickness in.	Nominal ID in. (mm)	Shipping Weight lbs (kg)
¾ in.	FL00750300	1 ½	3.0 (76)	2.8 (71)	0.8 (20)	0.008	0.5 (12.7)	1.5 (0.7)
	FL00750600	1 ½	6.0 (152)	5.5 (140)	0.8 (20)	0.008	0.5 (12.7)	1.5 (0.7)
	FL00751000	1 ½	10.0 (254)	9.1 (231)	0.8 (20)	0.008	0.5 (12.7)	2.0 (0.9)
	FL00751200	1 ½	12.0 (305)	10.9 (271)	0.8 (20)	0.008	0.5 (12.7)	2.0 (0.9)
	FL00751800	1 ½	18.0 (457)	16.3 (414)	0.8 (20)	0.008	0.5 (12.7)	3.0 (1.4)
	FL00752000	1 ½	20.0 (508)	18.1 (460)	0.8 (20)	0.008	0.5 (12.7)	4.0 (1.8)
	FL00752400	1 ½	24.0 (610)	21.7 (551)	0.8 (20)	0.008	0.5 (12.7)	4.0 (1.8)
	FL00753600	1 ½	36.0 (914)	32.5 (826)	0.8 (20)	0.008	0.5 (12.7)	5.0 (2.3)
	FL00754800	1 ½	48.0 (1219)	43.3 (1100)	0.8 (20)	0.008	0.5 (12.7)	5.0 (2.3)
1 ½ in.	FL01500334	2 ¾	3.3 (85)	3.2 (80)	6.0 (152)	0.006	1.5 (38.1)	2.0 (0.9)
	FL01500400	2 ¾	4.0 (102)	3.7 (95)	6.0 (152)	0.006	1.5 (38.1)	2.0 (0.9)
	FL01501200	2 ¾	12.0 (305)	10.9 (278)	2.2 (56)	0.010	1.5 (38.1)	3.0 (1.4)
	FL01501800	2 ¾	18.0 (457)	16.3 (415)	2.2 (56)	0.010	1.5 (38.1)	4.0 (1.8)
	FL01502000	2 ¾	20.0 (508)	18.1 (461)	2.2 (56)	0.010	1.5 (38.1)	4.0 (1.8)
	FL01502400	2 ¾	24.0 (610)	21.7 (552)	2.3 (56)	0.010	1.5 (38.1)	5.0 (2.3)
	FL01503600	2 ¾	36.0 (914)	32.5 (827)	2.2 (56)	0.010	1.5 (38.1)	6.0 (2.7)
	FL01504800	2 ¾	48.0 (1220)	43.3 (1101)	2.2 (56)	0.010	1.5 (38.1)	6.0 (2.7)
	2 in.	FL02000600	3 ¾	6.0 (152)	5.6 (142)	7.5 (191)	0.006	2.0 (50.8)
FL02001200		3 ¾	12.0 (305)	11.0 (279)	2.6 (66)	0.012	2.0 (50.8)	5.0 (2.3)
2 ½ in.	FL02500625	4 ½	6.3 (159)	5.9 (149)	10.0 (254)	0.006	2.5 (63.5)	7.0 (3.2)
	FL02501200	4 ½	12.0 (305)	11.0 (280)	3.2 (81)	0.012	2.5 (63.5)	8.0 (3.6)
	FL02501800	4 ½	18.0 (457)	16.4 (417)	3.2 (81)	0.012	2.5 (63.5)	9.0 (4.1)
	FL02502000	4 ½	20.0 (508)	18.2 (463)	3.2 (81)	0.012	2.5 (63.5)	9.0 (4.1)
	FL02502400	4 ½	24.0 (610)	21.8 (554)	3.2 (81)	0.012	2.5 (63.5)	9.0 (4.1)
	FL02503600	4 ½	36.0 (914)	32.6 (829)	3.2 (81)	0.012	2.5 (63.5)	10.0 (4.5)
4 in.	FL04000763	6	7.6 (194)	7.1 (180)	19.0 (483)	0.010	4.0 (101.6)	14.0 (6.4)
	FL04001200	6	12.0 (305)	11.0 (280)	4.5 (114)	0.016	4.0 (101.6)	16.0 (7.3)
	FL04001800	6	18.0 (457)	16.4 (418)	4.5 (114)	0.016	4.0 (101.6)	17.0 (7.7)
	FL04002400	6	24.0 (610)	21.8 (555)	4.5 (114)	0.016	4.0 (101.6)	18.0 (8.2)

NOTE • Custom configurations available on request
• Clear Hole ConFlat Flange

ConFlat Fittings

Flexible Couplings (Braided)

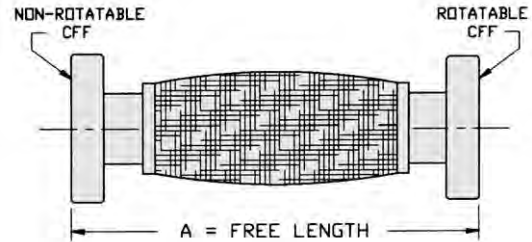
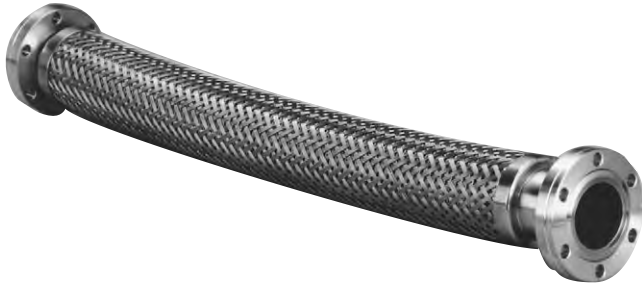

Specifications

- Vacuum-compatible stainless steel
- Sizes ¼ in. – 6 in.
- Full penetration vacuum welds

Ordering Information

Nominal O.D.	Part Number	Flange Size	Length Free A in. (mm)	Static Bend Radius in. (mm)	Bellows Wall Thickness in.	Nominal ID in. (mm)	Shipping Weight lbs (kg)
¾ in.	FLB00750600	1 ½	6.0 (152)	2.1 (53)	0.008	0.75 (19.1)	1.5 (0.7)
	FLB00751200	1 ½	12.0 (305)	2.1 (53)	0.008	0.75 (19.1)	2.0 (0.9)
	FLB00751800	1 ½	18.0 (457)	2.1 (53)	0.008	0.75 (19.1)	3.0 (1.4)
	FLB00752000	1 ½	20.0 (508)	2.1 (53)	0.008	0.75 (19.1)	4.0 (1.8)
	FLB00752400	1 ½	24.0 (610)	2.1 (53)	0.008	0.75 (19.1)	4.0 (1.8)
	FLB00753600	1 ½	36.0 (914)	2.1 (53)	0.008	0.75 (19.1)	5.0 (2.3)
	FLB00754800	1 ½	48.0 (1219)	2.1 (53)	0.008	0.75 (19.1)	5.0 (2.3)
1 ½ in.	FLB01500600	2 ¾	6.0 (152)	3.9 (99)	0.010	1.50 (38.1)	2.0 (0.9)
	FLB01501200	2 ¾	12.0 (305)	3.9 (99)	0.010	1.50 (38.1)	3.0 (1.4)
	FLB01501875	2 ¾	18.8 (478)	3.9 (99)	0.010	1.50 (38.1)	4.0 (1.8)
	FLB01502000	2 ¾	20.0 (508)	3.9 (99)	0.010	1.50 (38.1)	4.0 (1.8)
	FLB01502400	2 ¾	24.0 (610)	3.9 (99)	0.010	1.50 (38.1)	5.0 (2.3)
	FLB01503600	2 ¾	36.0 (914)	3.9 (99)	0.010	1.50 (38.1)	6.0 (2.7)
	FLB01504800	2 ¾	48.0 (1219)	3.9 (99)	0.010	1.50 (38.1)	6.0 (2.7)
2 ½ in.	FLB02502400	4 ½	24.0 (610)	5.9 (150)	0.012	2.50 (63.5)	9.0 (4.1)
	FLB02503600	4 ½	36.0 (914)	5.9 (150)	0.012	2.50 (63.5)	10.0 (4.5)
	FLB02504800	4 ½	48.0 (1219)	5.9 (150)	0.012	2.50 (63.5)	10.0 (4.5)

NOTE • Custom configurations available on request
 • Clear Hole ConFlat Flange

Components

CFF to KF Adapters

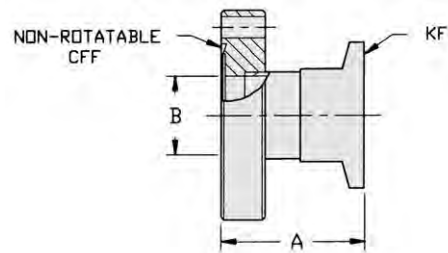

Ordering Information

CFF Size	Part Number	CFF OD	KF Flange NW Size OD	Overall Length A in. (mm)	Tube ID B in. (mm)	Weight lbs (kg)
1 1/3 in.	FA0133NW16S	1.33	NW16 1.18	1.57 (39.88)	0.68 (17.27)	1.0 (0.5)
	FA0133NW16	1.33	NW16 1.18	2.00 (50.80)	0.68 (17.27)	1.0 (0.5)
	FA0133NW16L	1.33	NW16 1.18	2.07 (52.70)	0.68 (17.27)	1.0 (0.5)
	FA0133NW25	1.33	NW25 1.57	2.00 (50.80)	0.68 (17.27)	1.5 (0.7)
	FA0133NW40	1.33	NW40 2.16	1.57 (39.88)	0.68 (17.27)	1.5 (0.7)
	FA0133NW50	1.33	NW50 2.95	2.00 (50.80)	0.68 (17.27)	1.5 (0.7)
2 3/4 in.	FA0275NW16S	2.73	NW16 1.18	1.78 (45.21)	0.68 (17.27)	1.5 (0.7)
	FA0275NW16	2.73	NW16 1.18	2.00 (50.80)	0.68 (17.27)	1.5 (0.7)
	FA0275NW16L	2.73	NW16 1.18	2.36 (59.94)	0.68 (17.27)	1.5 (0.7)
	FA0275NW25S	2.73	NW25 1.57	1.78 (45.21)	0.87 (22.10)	1.5 (0.7)
	FA0275NW25	2.73	NW25 1.57	2.00 (50.80)	0.87 (22.10)	1.5 (0.7)
	FA0275NW25L	2.73	NW25 1.57	2.36 (59.94)	0.87 (22.10)	1.5 (0.7)
	FA0275NW40S	2.73	NW40 2.16	1.78 (45.21)	1.37 (34.80)	2.0 (0.9)
	FA0275NW40	2.73	NW40 2.16	2.00 (50.80)	1.37 (34.80)	2.0 (0.9)
	FA0275NW40L	2.73	NW40 2.16	2.55 (64.77)	1.37 (34.80)	2.0 (0.9)
4 1/2 in.	FA0450NW40	4.47	NW40 2.16	2.00 (50.80)	1.37 (34.80)	3.0 (1.4)
	FA0450NW50L	4.47	NW50 2.95	2.00 (50.80)	1.87 (47.50)	3.0 (1.4)
	FA0450NW50	4.47	NW50 2.95	1.95 (49.53)	1.87 (34.80)	3.0 (1.4)

Accessories

Size	Description	Part Number	Qty/Pkg	Shipping Weight lbs (kg)
NW16	Viton centering ring	KC16SV	1	0.5 (0.2)
NW25	Viton centering ring	KC25SV	1	0.5 (0.2)
NW40	Viton centering ring	KC40SV	1	0.5 (0.2)
NW50	Viton centering ring	KC50SV	1	0.5 (0.2)
NW16	KF clamp	KQ16AR	1	0.5 (0.2)
NW25	KF clamp	KQ25AR	1	0.5 (0.2)
NW40	KF clamp	KQ40AR	1	1.0 (0.5)
NW50	KF clamp	KQ50AR	1	1.0 (0.5)

NOTE • Custom adapters available on request
• Clear Hole ConFlat Flange

ConFlat Fittings

Adapters: ConFlat to Swagelok



Ordering Information

Flange Size	Tube Size	Part Number	Length in. (mm)	Shipping Weight lbs (kg)
1 1/3 in.	1/4 in.	FASW0250133	1.37 (34.8)	0.5 (0.22)
2 3/4 in.	1/4 in.	FASW0250275	1.53 (38.9)	1.0 (0.45)
1 1/3 in.	3/8 in.	FASW0375133	1.66 (42.2)	0.5 (0.22)
2 3/4 in.	3/8 in.	FASW0375275	1.69 (42.9)	1.0 (0.45)
2 3/4 in.	1/2 in.	FASW0500275	1.83 (46.5)	1.0 (0.45)
2 3/4 in.	3/4 in.	FASW0750275	2.20 (55.9)	1.0 (0.45)
2 3/4 in.	1 in.	FASW1000275	2.67 (67.8)	1.0 (0.45)

NOTE • Clear Hole ConFlat Flange

Adapters: ConFlat to VCR - Male & Female



Ordering Information

Flange Size	Tube Size	Part Number	Length in. (mm)	Shipping Weight lbs (kg)
Male				
1½ in.	¼ in.	FAVM0250133	1.36 (34.5)	0.5 (0.22)
2¾ in.	¼ in.	FAVM0250275	1.52 (38.6)	1.0 (0.45)
1½ in.	¾ in.	FAVM0375133	1.55 (39.4)	0.5 (0.22)
2¾ in.	¾ in.	FAVM0375275	1.71 (43.4)	1.0 (0.45)
1½ in.	½ in.	FAVM0500133	1.55 (39.4)	0.5 (0.22)
2¾ in.	½ in.	FAVM0500275	1.71 (43.4)	1.0 (0.45)
2¾ in.	¾ in.	FAVM0750275	2.21 (56.1)	1.0 (0.45)
2¾ in.	1 in.	FAVM1000275	2.43 (61.7)	1.0 (0.45)
Female				
1½ in.	¼ in.	FAVF0250133	1.36 (34.5)	0.5 (0.22)
2¾ in.	¼ in.	FAVF0250275	1.52 (38.6)	1.0 (0.45)
1½ in.	¾ in.	FAVF0375133	1.55 (39.4)	0.5 (0.22)
2¾ in.	¾ in.	FAVF0375275	1.71 (43.4)	1.0 (0.45)
1½ in.	½ in.	FAVF0500133	1.55 (39.4)	0.5 (0.22)
2¾ in.	½ in.	FAVF0500275	1.71 (43.4)	1.0 (0.45)
2¾ in.	¾ in.	FAVF0750275	2.21 (56.1)	1.0 (0.45)
2¾ in.	1 in.	FAVF1000275	2.43 (61.7)	1.0 (0.45)

NOTE • Clear Hole ConFlat Flange

ConFlat Fittings

UHV Compression Ports

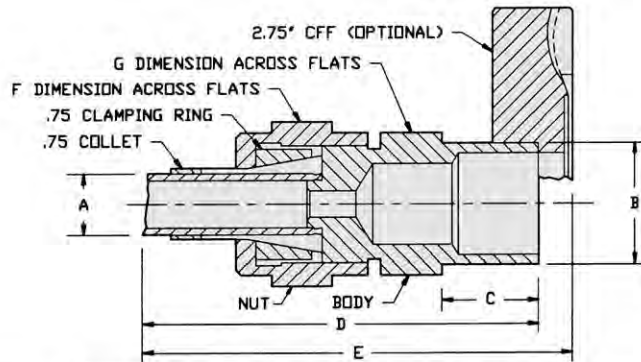

	A	B	C	D	E	F	G
3/4" ASSY	.75 (19.1)	1.00 (24.5)	.66 (16.7)	2.63 (66.8)	3.00 (76.2)	1.38 (35.0)	1.19 (30.2)
3/8" ASSY	.38 (9.7)	.75 (19.1)	.63 (16.0)	2.31 (55.7)	2.53 (64.3)	.88 (22.4)	.77 (19.6)
1/2" ASSY	.50 (12.7)	.75 (19.1)	.65 (16.5)	2.63 (66.8)	2.81 (71.4)	1.13 (28.7)	1.00 (25.4)

Dimensions: inches (millimeters)

Specifications

- Vacuum range: 10^{-11} Torr (mbar)
- Bakeout Temperature: 500° C

Ordering Information

Description	Part Number	Shipping Weight lbs (kg)
Compression Port with Felpro Lubricant		
3/8 in. (9.9 mm) port	CP0038UHV	2.0 (0.9)
3/8 in. (9.9 mm) port on 2.75 (NW35) ConFlat	FCP0038UHV	3.0 (1.3)
1/2 in. (12.7 mm) port	CP0050UHV	2.0 (0.9)
1/2 in. (12.7 mm) port on 2.75 (NW35) ConFlat	FCP0050UHV	3.0 (1.3)
3/4 in. (19 mm) port	CP0075UHV	2.0 (0.9)
3/4 in. (19 mm) port on 2.75 (NW35) ConFlat	FCP0075UHV	3.0 (1.3)
Combination Compression Port Body and Nut		
Will accept 3/4 in. (19 mm) tubulation	CP0075UHVC	0.8 (0.4)
3/4 in. (19 mm) Assembly		
Includes collet, clamping ring, and Felpro lubricant	CP0075UHVA	1.0 (0.5)
Compression Port Rebuild Kits		
3/8 in. (9.9 mm) ports	CP0038RK	1.0 (0.5)
1/2 in. (12.7 mm) ports	CP0050RK	1.0 (0.5)
3/4 in. (19 mm) ports	CP0075RK	1.0 (0.5)
OFHC Copper Tubulations 6 in. (152.4 mm) Long		
3/8 in. (9.9 mm) OD, .032 wall thickness	CP0038CT	1.0 (0.5)
1/2 in. (12.7 mm) OD, .035 wall thickness	CP0050CT	1.0 (0.5)
3/4 in. (19 mm) OD, .035 wall thickness	CP0075CT	2.0 (0.9)
OFHC Copper Adapters		
3/8 in. (9.9 mm) port adapter with 1.33 (NW16) ConFlat gasket/package of 4	CP00380133CA	1.5 (0.7)
3/8 in. (9.9 mm) port adapter with 2.75 (NW35) ConFlat gasket/package of 4	CP00380275CA	1.5 (0.7)

Con Flat to Compression Port Adapters

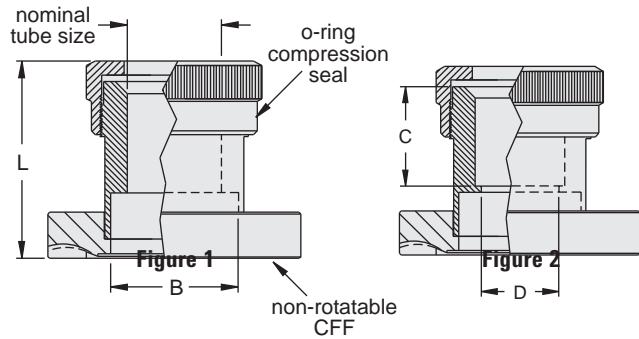

Specifications

- Stainless steel
- Viton o-ring
- Use with glass gauges or standard metal tubing
- Hand-tightened compression fitting

Ordering Information

Nominal Tube Size	Part Number	Bore ID B in. (mm)	Length L in. (mm)	Flange Size	ID C in. (mm)	Tube Stop D in. (mm)	Fig. Number	Weight lbs (kg)
1/16 in.	FCP00600133	0.63 (16.00)	1.67 (42.67)	1.33	—	—	1	2.0 (0.9)
	FCP00600275	0.63 (16.00)	1.71 (43.43)	2.75	—	—	1	2.0 (0.9)
1/8 in.	FCP01250133	0.63 (16.00)	1.67 (42.67)	1.33	—	—	1	2.0 (0.9)
	FCP01250275	0.63 (16.00)	1.71 (43.43)	2.75	—	—	1	2.0 (0.9)
3/16 in.	FCP01900133	0.63 (16.00)	1.67 (42.67)	1.33	—	—	1	2.0 (0.9)
	FCP01900275	0.63 (16.00)	1.71 (43.43)	2.75	—	—	1	2.0 (0.9)
1/4 in.	FCP02500133	0.63 (16.00)	1.67 (42.67)	1.33	—	—	1	2.0 (0.9)
	FCP02500275	0.63 (16.00)	1.71 (43.43)	2.75	—	—	1	2.0 (0.9)
5/16 in.	FCP03750133	0.63 (16.00)	1.67 (42.67)	1.33	—	—	1	2.0 (0.9)
	FCP03750275	0.63 (16.00)	1.71 (43.43)	2.75	—	—	1	2.0 (0.9)
1/2 in.	FCP05000133	0.63 (16.00)	1.67 (42.67)	1.33	—	—	1	2.0 (0.9)
	FCP05000275	0.63 (16.00)	1.71 (43.43)	2.75	—	—	1	2.0 (0.9)
3/4 in.	FCP07500275	1.38 (35.05)	2.02 (51.31)	2.75	0.63 (16.00)	1.13 (28.70)	2	2.0 (0.9)
7/8 in.	FCP08750275	1.38 (35.05)	2.02 (51.31)	2.75	—	—	1	2.0 (0.9)
1 in.	FCP10000275	1.38 (35.05)	2.08 (52.83)	2.75	0.88 (22.35)	1.13 (28.70)	2	2.0 (0.9)
1 1/8 in.	FCP11250275	1.38 (35.05)	2.08 (52.83)	2.75	—	—	1	2.0 (0.9)

NOTE • Custom configurations available on request
 • Clear Hole ConFlat Flange

ConFlat Fittings

O-Ring Sealed Vacuum Compression Ports and Blank-offs

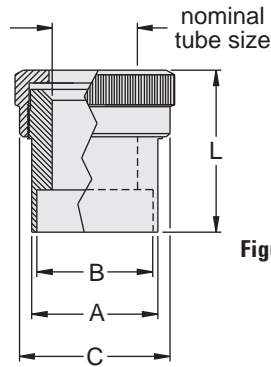

Figure 1

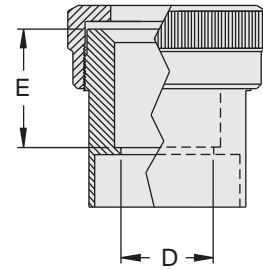

Figure 2

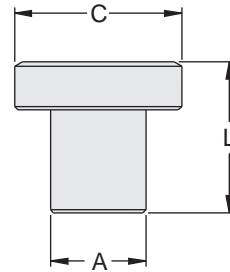
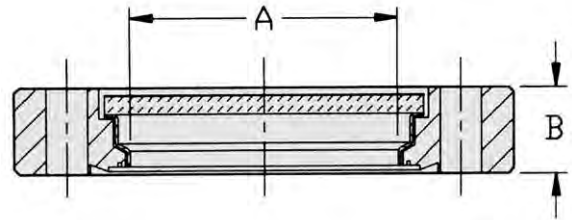

Figure 3

Ordering Information

Nominal Tube Size	Part Number	Fig. Number	Body OD		Bore ID		OD		Length		I.D.		Tube Stop		Weight lbs (kg)
			A in. (mm)	B in. (mm)	C in. (mm)	L in. (mm)	D in. (mm)	E in. (mm)							
1/8 in.	CP0125S	1	0.75 (19.05)	0.63 (16.00)	1.14 (28.96)	1.50 (38.10)	—	—	1.0 (0.5)						
3/16 in.	CP0190S	1	0.75 (19.05)	0.63 (16.00)	1.14 (28.96)	1.50 (38.10)	—	—	1.0 (0.5)						
1/4 in.	CP0250S	1	0.75 (19.05)	0.63 (16.00)	1.14 (28.96)	1.50 (38.10)	—	—	1.0 (0.5)						
5/16 in.	CP0312S	1	0.75 (19.05)	0.63 (16.00)	1.14 (28.96)	1.50 (38.10)	—	—	1.0 (0.5)						
3/8 in.	CP0375S	1	0.75 (19.05)	0.63 (16.00)	1.14 (28.96)	1.50 (38.10)	—	—	1.0 (0.5)						
1/2 in.	CP0500S	1	0.75 (19.05)	0.63 (16.00)	1.14 (28.96)	1.50 (38.10)	—	—	1.0 (0.5)						
5/8 in.	CP0625S	1	0.75 (19.05)	0.63 (16.00)	1.14 (28.96)	1.50 (38.10)	—	—	1.0 (0.5)						
3/4 in.	CP0750S	1	1.50 (38.10)	1.38 (35.05)	1.89 (48.01)	1.88 (47.75)	—	—	1.0 (0.5)						
7/8 in.	CP0875S	1	1.50 (38.10)	1.38 (35.05)	1.89 (48.01)	1.88 (47.75)	—	—	1.0 (0.5)						
1 in.	CP1000S	2	1.50 (38.10)	1.38 (35.05)	1.89 (48.01)	1.88 (47.75)	0.88 (22.35)	1.13 (28.70)	1.0 (0.5)						
1 1/8 in.	CP1125S	1	1.50 (38.10)	1.38 (35.05)	1.89 (48.01)	1.88 (47.75)	—	—	1.0 (0.5)						
1 1/4 in.	CP1250S	1	1.50 (38.10)	1.38 (35.05)	1.89 (48.01)	1.88 (47.75)	—	—	1.0 (0.5)						
1 3/8 in.	CP1375S	1	1.75 (44.45)	1.63 (41.40)	2.26 (57.40)	2.25 (57.15)	—	—	1.0 (0.5)						
1 1/2 in.	CP1500S	1	1.75 (44.45)	1.63 (41.40)	2.26 (57.40)	2.25 (57.15)	—	—	1.0 (0.5)						

Zero-Length Glass Viewports



Specifications

- Transmission Range: 0.32 to 2.7 microns (approx.)
- Vacuum Range: To below 10^{-11} Torr (mbar)
- Viewport Type: 7056 Glass
- Bakeout Temperature: 400° C

Ordering Information

Description	ConFlat Size	Part Number	Nominal Port Diameter in. (mm)	A in. (mm)	B in. (mm)	Weight lbs (kg)
¾ in. (14 mm) Viewport	1.33 in. (NW16)	FVG0075	0.75 (19.05)	0.63 (16)	0.50 (12.70)	1.0 (0.5)
1½ in. (36 mm) Viewport	2.75 in. (NW35)	FVG0150	1.50 (38.10)	1.50 (38)	0.50 (12.70)	2.0 (0.9)
2½ in. (63.5 mm) Viewport	4.50 in. (NW63)	FVG0250	2.50 (63.50)	2.48 (63)	0.68 (17.40)	5.0 (2.3)
4 in. (98 mm) Viewport	6 in. (NW100)	FVG0400	4.00 (101.60)	3.50 (89)	0.78 (19.90)	6.0 (2.7)
6 in. (137 mm) Viewport	8 in. (NW150)	FVG0600	6.00 (152.40)	5.35 (136)	0.92 (23.37)	9.0 (4.0)

NOTE • Clear Hole ConFlat Flange

ConFlat Fittings

Sapphire Viewports - Zero Length

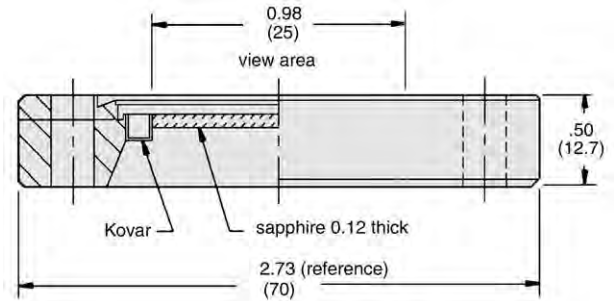

Dimensions: inches (millimeters)

Specifications

- Transmission Range: 0.25 to 5.5 microns (approx.)
- Vacuum Range: To below 10^{-11} Torr (mbar)
- Bakeout Temperature: 450° C

Ordering Information

Description	Part Number	Weight lbs (kg)
1 in. (25.4 mm) Zero Length Sapphire/Kovar Viewport on 2.75 (NW35) ConFlat flange	FVS0100	2.0 (0.9)

- NOTE**
- Custom viewports available on request
 - Clear Hole ConFlat Flange

Sapphire Viewports - Standard Length

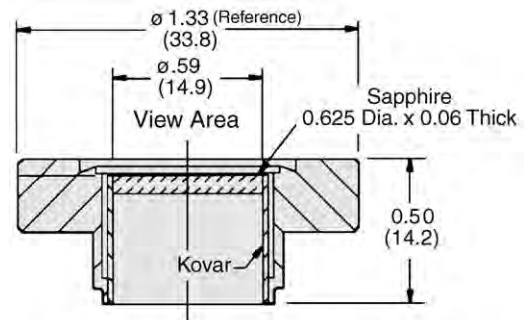

Dimensions: inches (millimeters)

Specifications

- Transmission Range: .25 to 5.5 microns (approx.)
- Vacuum Range: To below 10^{-11} Torr (mbar)
- Bakeout Temperature: 450° C

Ordering Information

Description	Part Number	Shipping Weight lbs (kg)
5/8 in. (15.8 mm) Standard Length Sapphire/Kovar Viewport on 1.33 (NW13) ConFlat flange	FVS0062	1.0 (0.5)

- NOTE**
- Custom viewports available on request
 - Clear Hole ConFlat Flange

VacuumXpress

Glass Adapters with Bellows

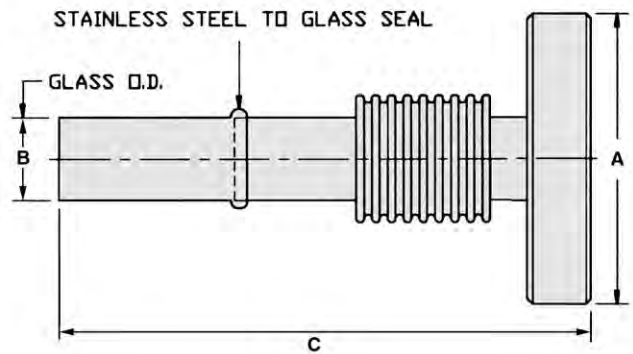

Specifications

- Vacuum Range: To below 10^{-11} Torr (mbar)
- Bakeout Temperature: 400° C
- Pyrex 7740 Glass

Ordering Information

Description	Part Number	A in. (mm)	B in. (mm) (Reference)	C in. (mm)	Shipping Weight lbs (kg)
6 mm OD Glass Adapter with bellows and mini ConFlat flange	FGAB7	1.33 (34.0)	0.24 (6.0)	6.69 (170.0)	1.0 (0.5)
10 mm OD Glass Adapter with bellows and mini ConFlat flange	FGAB10	1.33 (34.0)	0.39 (10.0)	5.50 (140.0)	1.0 (0.5)
13 mm OD Glass Adapter with bellows and mini ConFlat flange	FGAB13	1.33 (34.0)	0.51 (13.0)	6.69 (170.0)	2.0 (0.9)
19 mm OD Glass Adapter with bellows and 2.75 ConFlat flange	FGAB19	2.75 (70.0)	0.75 (19.0)	7.48 (190.0)	2.0 (0.9)

- NOTE**
- Custom configurations available on request
 - Clear Hole ConFlat Flange

ConFlat Fittings

Glass Adapters

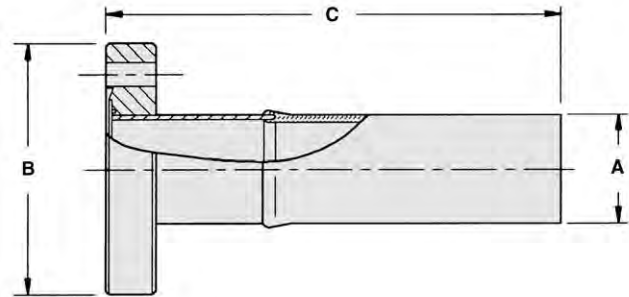

Specifications

- Vacuum Range: To below 10^{-11} Torr (mbar)
- Bakeout Temperature: 400° C
- Glass Type: see ordering information table

Ordering Information

Description	Part Number	A in. (mm) Nom.	B in. (mm) (Reference)	C in. (mm)	Weight lbs (kg)
¼ in. Kovar to Pyrex Glass Adapter on 1.33 (NW16) ConFlat	FGA0025KP	0.24 (6.0)	1.33 (34.0)	3.94 (100.0)	1.5 (0.7)
¼ in. Stainless Steel to Pyrex Glass Adapter on 1.33 (NW16) ConFlat	FGA0025SP	0.24 (6.0)	1.33 (34.0)	4.88 (124.0)	1.5 (0.7)
½ in. Kovar to Pyrex Glass Adapter on 1.33 (NW16) ConFlat	FGA0050KP	0.51 (13.0)	1.33 (34.0)	3.94 (100.0)	1.5 (0.7)
½ in. Stainless Steel to Pyrex Glass Adapter on 1.33 (NW16) ConFlat	FGA0050SP	0.51 (13.0)	1.33 (34.0)	4.88 (124.0)	1.5 (0.7)
¾ in. Kovar to Pyrex Glass Adapter on 1.33 (NW16) ConFlat	FGA0075KP	0.75 (19.0)	1.33 (34.0)	5.38 (137.0)	1.5 (0.7)
¾ in. Stainless Steel to Pyrex Glass Adapter on 1.33 (NW16) ConFlat	FGA0075SP	0.75 (19.0)	1.33 (34.0)	4.88 (124.0)	1.5 (0.7)
1 in. Kovar to Pyrex Glass Adapter on 2.75 (NW35) ConFlat	FGA0100KP	1.00 (25.0)	2.75 (70.0)	3.94 (100.0)	3.0 (1.4)
1 in. Stainless Steel to Pyrex Glass Adapter on 2.75 (NW35) ConFlat	FGA0100SP	1.00 (25.0)	2.75 (70.0)	4.88 (124.0)	3.0 (1.4)
1½ in. Kovar to Pyrex Glass Adapter on 2.75 (NW35) ConFlat	FGA0150KP	1.57 (40.0)	2.75 (70.0)	3.94 (100.0)	4.0 (1.8)
1½ in. Stainless Steel to Pyrex Glass Adapter on 2.75 (NW35) ConFlat	FGA0150SP	1.50 (38.0)	2.75 (70.0)	4.88 (124.0)	4.0 (1.8)
2½ in. Stainless Steel to Pyrex Glass Adapter on 4.5 (NW63) ConFlat	FGA0250SP	2.50 (64.0)	4.50 (114.0)	5.33 (137.0)	5.0 (2.3)

NOTE • Custom configurations available on request
• Clear Hole ConFlat Flange

VacuumXpress

Components

UHV Wire-Sealed Flange - Wheeler

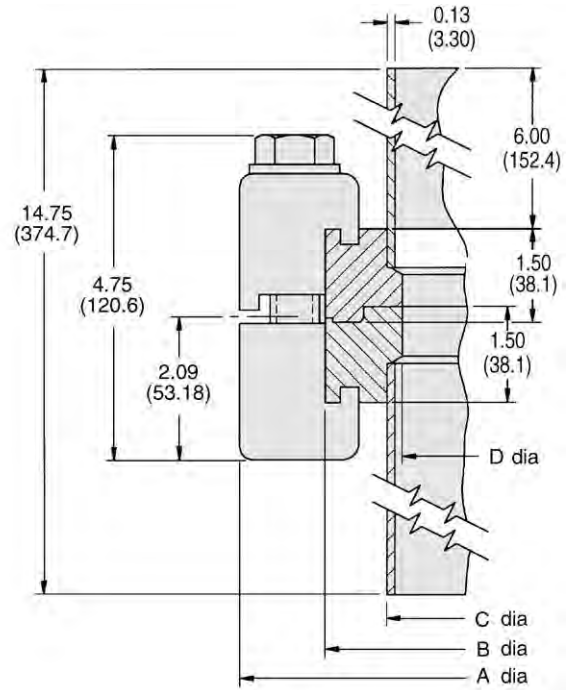

Dimensions: inches (millimeters)

Specifications

- Vacuum Range: To below 10^{-11} Torr (mbar)
- -169°C to $+450^{\circ}\text{C}$

Accessories

Part Number	Gasket ID	Gasket Thickness (in.)	Qty/Pkg	Shipping Weight lbs (kg)
Copper Gaskets				
WG1200	13.74 (349.0)	0.091	3	2.0 (.9)
WG1400	15.74 (399.8)	0.091	3	2.0 (.9)
WG1800	19.74 (501.4)	0.091	3	3.0 (1.3)
Clamp Assembly				
WCSI			1	.5 (.2)

Klamps Flanges & Fittings

Agilent Klamp, ISO & ASA-Flanges

Agilent's introduction of its extensive offering in vacuum flanges and fittings features an intuitive part numbering format. These part numbering format allows the customer to identify the product by the characters contained within the part number.

Depending on the product, the number and format of the characters in the part number will vary. Please see the examples below:

KF Flange Example

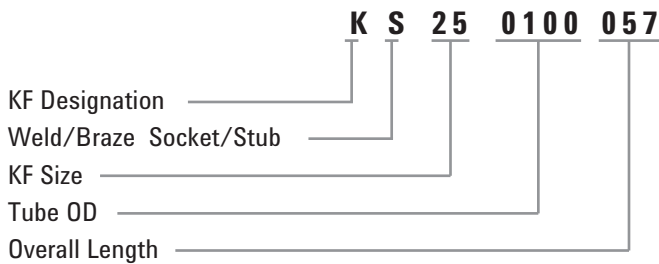

KF25 to 40 Conical Reducer Example

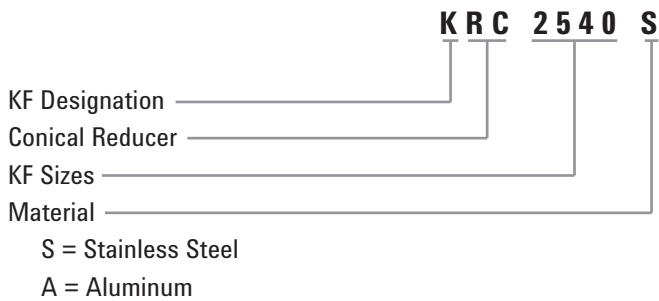

Klump-Flanges

Designed in accordance with ISO standards the Agilent KF flange can be used in a variety of applications from atmospheric pressure to high vacuum. The KF flange is manufactured from 304 stainless steel and has a leak rate less than $1E^{-9}$ std cc/sec and can be baked to 150° C when using a Viton O-Ring.

Klump Fittings

Employing the easy release clamping design, these fittings offer a quick and simple solution to vacuum system design and assembly. Bakeable to 150° C when using Viton O-Rings, these fittings are ideal for roughing or high vacuum applications.

Klump-Flanges & Fittings

Page

Quick Clamps	47
Centering Rings	49
Replacement O-Rings	52
Blank-Off Flanges	53
Unbored Stubs	55
Weld Sockets	56
Weld Stubs	57
Nipples	59
Elbows	60
Tees.....	61
4-Way Crosses	62
Reducers	62
KF to CFF Adapters	64
Pipe Adapters.....	66
Flexible Couplings	70
Compression Port Adapters	72
Swagelok and VCR Adapters	74
PVC Cord-reinforced Flexible Vacuum Hose	76
Aluminum Hose Adapter.....	76

Quick Clamps with Ratchet Closure NW10 - NW50 (ISO)

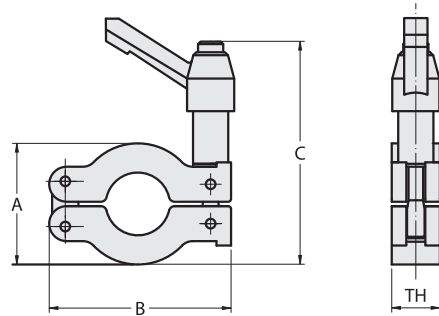

Specifications

- Aluminum
- Black or Metallic Finish

Ordering Information – (Black or Metallic Finish)

Description	Black	Metallic	A in. (mm)	B in. (mm)	C in. (mm)	Thickness in. (mm)	Weight lbs (kg)
NW10/16	KQ16AR	KQ16ARP	1.57 (40.00)	2.45 (62.30)	3.12 (79.25)	0.65 (16.50)	1.0 (0.5)
NW25	KQ25AR	KQ25ARP	2.13 (54.00)	2.85 (72.40)	3.38 (85.85)	0.65 (16.50)	1.0 (0.5)
NW40	KQ40AR	KQ40ARP	2.68 (68.00)	3.53 (89.70)	3.67 (93.22)	0.65 (16.50)	1.0 (0.5)
NW50	KQ50AR	KQ50ARP	3.54 (90.00)	4.80 (122.00)	4.42 (112.27)	0.91 (23.20)	1.0 (0.5)

Quick Clamps with Wing-Nut Closure NW10 - NW50 (ISO)

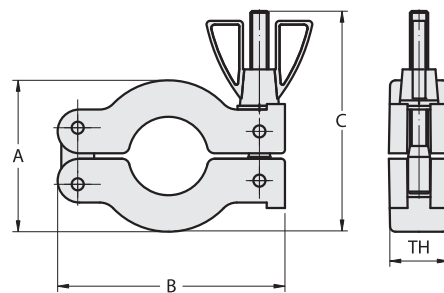

Specifications

- Aluminum
- Black or Plain finish

Ordering Information – (Black or Metallic Finish)

Description	Black	Metallic	A in. (mm)	B in. (mm)	C in. (mm)	Thickness in. (mm)	Weight lbs (kg)
NW10/16	KQ16AW	KQ16AWP	1.57 (40.00)	2.45 (62.30)	2.17 (55.19)	0.65 (16.50)	1.0 (0.5)
NW25	KQ25AW	KQ25AWP	2.13 (54.00)	2.85 (72.40)	2.37 (60.20)	0.65 (16.50)	1.0 (0.5)
NW40	KQ40AW	KQ40AWP	2.68 (68.00)	3.53 (89.70)	2.64 (67.06)	0.65 (16.50)	1.0 (0.5)
NW50	KQ50AW	KQ50AWP	3.54 (90.00)	4.80 (122.00)	3.60 (90.44)	0.91 (23.20)	1.0 (0.5)

Klamps Flanges & Fittings

Bulkhead Clamps

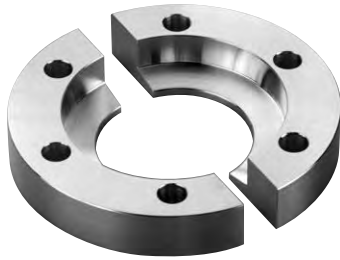

Specifications

- Aluminum
- Provides simple and secure baseplate connection
- Stainless Steel bolts and washers included (10-32 x 5/8)

Ordering Information

Description	Part Number	Bolts	Shipping Weight lbs (kg)
NW16	KBC16	6	0.5 (0.2)
NW25	KBC25	6	0.5 (0.2)
NW40	KBC40	6	0.5 (0.2)
NW50	KBC50	8	0.5 (0.2)

Bulkhead Claw Clamp Kit

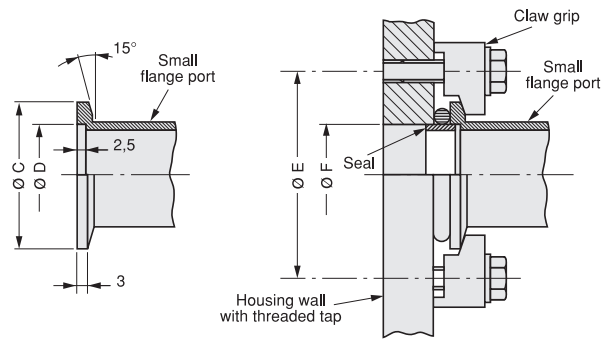
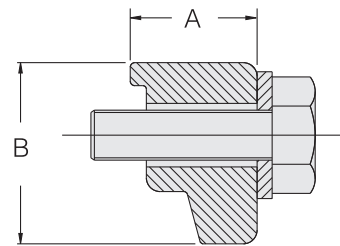
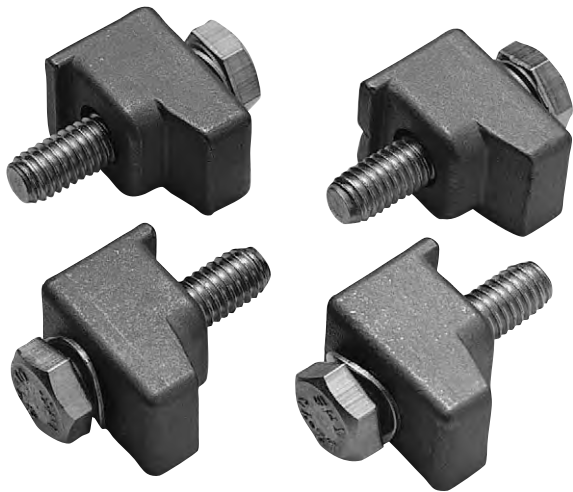

Specifications

- Cast steel
- Spring loaded lock-washers, Single Claw Clamp Kit for bolting KF flanges to bulkheads
- Can be used instead of bulkhead clamps

Nominal Diameter	C	D	E	F	Nr. of Claw Grips
DN 10 KF	30	12.2	45	12.2	4
DN 16 KF	30	17.2	45	17.2	4
DN 25 KF	44	26.2	55	26.2	4
DN 40 KF	55	41.2	71	41.2	4
DN 50 KF	75	52.4	91	52.2	4

Dimensions: millimeters

Ordering Information

Description	Part Number	Qty	A in. (mm)	B in. (mm)	Bolt	Shipping Weight lbs (kg)
NW25 to NW50	KF1050CCS	4	.55 (14)	.79 (20)	M6 x 20 mm	.11 (.05)

Stainless Steel Centering Rings NW10 – NW50 (ISO)

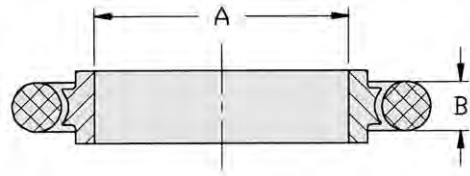

Specifications

- 304 stainless steel centering ring
- Replaceable o-ring
- 100° C maximum, Buna-N
- 200° C maximum, Viton

Ordering Information – Centering Rings (Viton)

Description	Part Number	A in. (mm)	B in. (mm)	Shipping Weight lbs (kg)
NW10	KC10SV	0.39 (9.91)	0.21 (5.33)	0.5 (0.2)
NW16	KC16SV	0.63 (16.00)	0.21 (5.33)	0.5 (0.2)
NW25	KC25SV	0.98 (24.89)	0.21 (5.33)	0.5 (0.2)
NW40	KC40SV	1.57 (39.88)	0.21 (5.33)	0.5 (0.2)
NW50	KC50SV	1.97 (50.04)	0.21 (5.33)	0.5 (0.2)

Ordering Information – Centering Rings (Buna-N)

Description	Part Number	A in. (mm)	B in. (mm)	Shipping Weight lbs (kg)
NW10	KC10SB	0.39 (9.91)	0.21 (5.33)	0.5 (0.2)
NW16	KC16SB	0.63 (16.00)	0.21 (5.33)	0.5 (0.2)
NW25	KC25SB	0.98 (24.89)	0.21 (5.33)	0.5 (0.2)
NW40	KC40SB	1.57 (39.88)	0.21 (5.33)	0.5 (0.2)
NW50	KC50SB	1.97 (50.04)	0.21 (5.33)	0.5 (0.2)

Ordering Information – Centering Rings (Silicon)

Description	Part Number	A in. (mm)	B in. (mm)	Shipping Weight lbs (kg)
NW10	KC10SS	0.39 (9.91)	0.21 (5.33)	0.5 (0.2)
NW16	KC16SS	0.63 (16.00)	0.21 (5.33)	0.5 (0.2)
NW25	KC25SS	0.98 (24.89)	0.21 (5.33)	0.5 (0.2)
NW40	KC40SS	1.57 (39.88)	0.21 (5.33)	0.5 (0.2)
NW50	KC50SS	1.97 (50.04)	0.21 (5.33)	0.5 (0.2)

Klamps Flanges & Fittings

Aluminum Centering Rings NW10 – NW50 (ISO)

Specifications

- 6061 T6 aluminum centering ring
- Replaceable o-ring
- 100° C maximum, Buna-N
- 200° C maximum, Viton

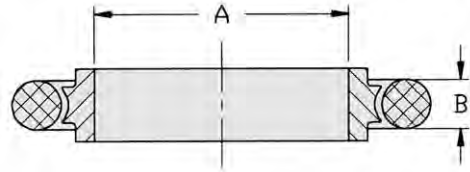

Ordering Information – Centering Rings (Viton)

Description	Part Number	A in. (mm)	B in. (mm)	Shipping Weight lbs (kg)
NW10	KC10AV	0.39 (9.91)	0.21 (5.33)	0.5 (0.2)
NW16	KC16AV	0.63 (16.00)	0.21 (5.33)	0.5 (0.2)
NW25	KC25AV	0.98 (24.89)	0.21 (5.33)	0.5 (0.2)
NW40	KC40AV	1.57 (39.88)	0.21 (5.33)	0.5 (0.2)
NW50	KC50AV	1.97 (50.04)	0.21 (5.33)	0.5 (0.2)

Ordering Information – Centering Rings (Buna-N)

Description	Part Number	A in. (mm)	B in. (mm)	Shipping Weight lbs (kg)
NW10	KC10AB	0.39 (9.91)	0.21 (5.33)	0.5 (0.2)
NW16	KC16AB	0.63 (16.00)	0.21 (5.33)	0.5 (0.2)
NW25	KC25AB	0.98 (24.89)	0.21 (5.33)	0.5 (0.2)
NW40	KC40AB	1.57 (39.88)	0.21 (5.33)	0.5 (0.2)
NW50	KC50AB	1.97 (50.04)	0.21 (5.33)	0.5 (0.2)

Adaptive Stainless Steel Centering Rings NW10 – NW40 (ISO)

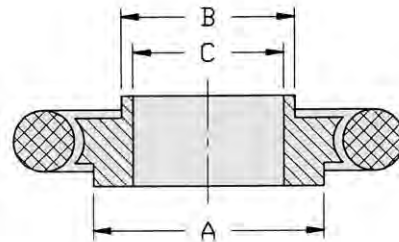

Specifications

- 304 stainless steel centering ring
- Replaceable o-ring
- 100° C maximum, Buna-N
- 200° C maximum, Viton

Ordering Information – Adaptive Centering Rings (Viton)

Description	Part Number	A in. (mm)	B in. (mm)	C in. (mm)	Shipping Weight lbs (kg)
NW10 to NW16	KCA1016SV	0.67 (17.02)	0.47 (11.94)	0.39 (9.91)	0.5 (0.2)
NW20 to NW25	KCA2025SV	1.02 (25.91)	0.87 (22.10)	0.79 (20.01)	0.5 (0.2)
NW32 to NW40	KCA3240SV	1.61 (40.89)	1.34 (34.04)	1.26 (32.00)	0.5 (0.2)

Ordering Information – Adaptive Centering Rings (Buna-N)

Description	Part Number	A in. (mm)	B in. (mm)	C in. (mm)	Shipping Weight lbs (kg)
NW10 to NW16	KCA1016SB	0.67 (17.02)	0.47 (11.94)	0.39 (9.91)	0.5 (0.2)
NW20 to NW25	KCA2025SB	1.02 (25.91)	0.87 (22.10)	0.79 (20.01)	0.5 (0.2)
NW32 to NW40	KCA3240SB	1.61 (40.89)	1.34 (34.04)	1.26 (32.00)	0.5 (0.2)

Adaptive Aluminum Centering Rings NW10 – NW40 (ISO)

Specifications

- 6061 T6 aluminum centering ring
- Replaceable o-ring
- 100° C maximum, Buna-N
- 200° C maximum, Viton

Ordering Information – Adaptive Centering Rings (Viton)

Description	Part Number	A in. (mm)	B in. (mm)	C in. (mm)	Shipping Weight lbs (kg)
NW10 to NW16	KCA1016AV	0.67 (17.02)	0.47 (11.94)	0.39 (9.91)	0.5 (0.2)
NW20 to NW25	KCA2025AV	1.02 (25.91)	0.87 (22.10)	0.79 (20.01)	0.5 (0.2)
NW32 to NW40	KCA3240AV	1.61 (40.89)	1.34 (34.04)	1.26 (32.00)	0.5 (0.2)

Ordering Information – Adaptive Centering Rings (Buna-N)

Description	Part Number	A in. (mm)	B in. (mm)	C in. (mm)	Shipping Weight lbs (kg)
NW10 to NW16	KCA1016AB	0.67 (17.02)	0.47 (11.94)	0.39 (9.91)	0.5 (0.2)
NW20 to NW25	KCA2025AB	1.02 (25.91)	0.87 (22.10)	0.79 (20.01)	0.5 (0.2)
NW32 to NW40	KCA3240AB	1.61 (40.89)	1.34 (34.04)	1.26 (32.00)	0.5 (0.2)

Stainless Steel Centering Rings with Screen NW16 – NW50 (ISO)

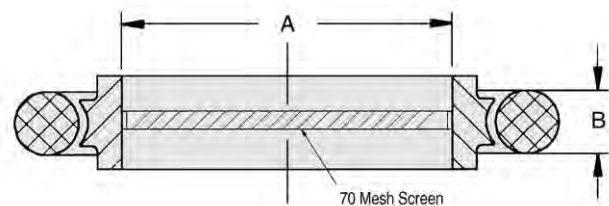

Specifications

- 304 stainless steel centering ring
- Replaceable o-ring
- 200° C maximum, Viton
- 70 mesh screen (0.2 x 0.2 x 0.15 mm)

Ordering Information – Centering Rings (Viton)

Description	Part Number	A in. (mm)	B in. (mm)	Shipping Weight lbs (kg)
NW16	KC16SV72M	0.37 (9.5)	0.25 (5)	0.5 (0.2)
NW25	KC25SV72M	0.77 (19.5)	0.25 (5)	0.5 (0.2)
NW40	KC40SV72M	1.26 (32.0)	0.25 (5)	0.5 (0.2)
NW50	KC50SV72M	1.67 (43.0)	0.25 (5)	0.5 (0.2)

Replacement O-Rings NW10 – NW50 (ISO)

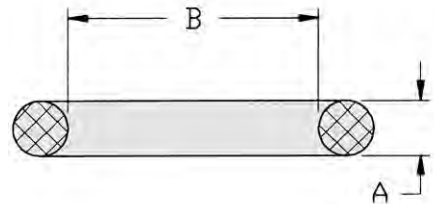
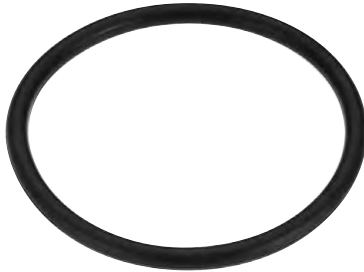

Specifications

- 100° C maximum, Buna-N
- 200° C maximum, Viton

Ordering Information – Replacement O-Rings (Viton)

Description	Part Number	Qty/Pkg	A in. (mm)	B in. (mm)	Shipping Weight lbs (kg)
NW10	KG10V	10	0.21 (5.33)	0.60 (15.24)	0.5 (0.2)
NW16	KG16V	10	0.21 (5.33)	0.73 (18.42)	0.5 (0.2)
NW25	KG25V	10	0.21 (5.33)	1.10 (27.94)	0.5 (0.2)
NW40	KG40V	10	0.21 (5.33)	1.60 (40.64)	0.5 (0.2)
NW50	KG50V	10	0.21 (5.33)	2.10 (53.34)	0.5 (0.2)

Ordering Information – Replacement O-Rings (Buna-N)

Description	Part Number	Qty/Pkg	A in. (mm)	B in. (mm)	Shipping Weight lbs (kg)
NW10	KG10B	10	0.21 (5.33)	0.60 (15.24)	0.5 (0.2)
NW16	KG16B	10	0.21 (5.33)	0.73 (18.42)	0.5 (0.2)
NW25	KG25B	10	0.21 (5.33)	1.10 (27.94)	0.5 (0.2)
NW40	KG40B	10	0.21 (5.33)	1.60 (40.64)	0.5 (0.2)
NW50	KG50B	10	0.21 (5.33)	2.10 (53.34)	0.5 (0.2)

Ordering Information – Replacement O-Rings (Silicon)

Description	Part Number	Qty/Pkg	A in. (mm)	B in. (mm)	Shipping Weight lbs (kg)
NW10	KG10S	10	0.21 (5.33)	0.60 (15.24)	0.5 (0.2)
NW16	KG16S	10	0.21 (5.33)	0.73 (18.42)	0.5 (0.2)
NW25	KG25S	10	0.21 (5.33)	1.10 (27.94)	0.5 (0.2)
NW40	KG40S	10	0.21 (5.33)	1.60 (40.64)	0.5 (0.2)
NW50	KG50S	10	0.21 (5.33)	2.10 (53.34)	0.5 (0.2)

Components

Blank-Off Flanges NW10 – NW50 (ISO)

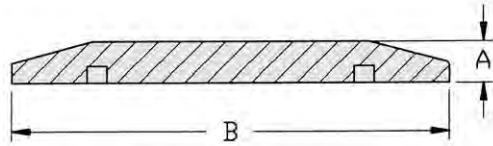

Specifications

- 304 stainless steel
- 6061 T6 aluminum
- Use as blank-off port
- Can be machined and welded

Ordering Information – Blank-Off Flanges (Stainless Steel)

Description	Part Number	A in. (mm)	B in. (mm)	Shipping Weight lbs (kg)
NW10/16	KF160000SB	0.20 (5.08)	1.18 (29.97)	0.5 (0.2)
NW25	KF250000SB	0.20 (5.08)	1.58 (40.13)	0.5 (0.2)
NW40	KF400000SB	0.20 (5.08)	2.17 (55.12)	0.5 (0.2)
NW50	KF500000SB	0.20 (5.08)	2.95 (74.93)	0.5 (0.2)

Ordering Information – Blank-Off Flanges (Aluminum)

Description	Part Number	A in. (mm)	B in. (mm)	Shipping Weight lbs (kg)
NW10/16	KF160000AB	0.20 (5.08)	1.18 (29.97)	0.5 (0.2)
NW25	KF250000AB	0.20 (5.08)	1.58 (40.13)	0.5 (0.2)
NW40	KF400000AB	0.20 (5.08)	2.17 (55.12)	0.5 (0.2)
NW50	KF500000AB	0.20 (5.08)	2.95 (74.93)	0.5 (0.2)

Klamps Flanges & Fittings

Bored Blank-Off Flanges NW16 – NW50 (ISO)

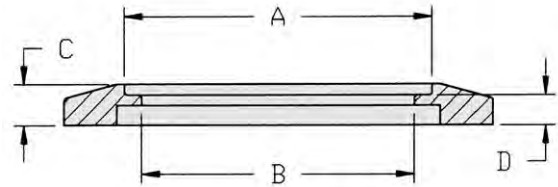

Specifications

- Self-aligning
- 304 stainless steel
- Standard inch size tubing
- Standard tube weld prep

Ordering Information

Description	Part Number	Tube Size A in. (mm)	B in. (mm)	C in. (mm)	D in. (mm)	Shipping Weight lbs (kg)
NW16 (0.50 in. tubing)	KS160050BB	0.51 (12.95)	0.44 (11.18)	0.17 (4.32)	0.15 (3.81)	0.5 (0.2)
	KS160075BB	0.76 (19.30)	0.69 (17.53)	0.17 (4.32)	0.15 (3.81)	0.5 (0.2)
NW25 (0.50 in. tubing)	KS250050BB	0.51 (12.95)	0.44 (11.18)	0.19 (4.82)	0.15 (3.81)	0.5 (0.2)
	KS250075BB	0.76 (19.30)	0.69 (17.53)	0.19 (4.82)	0.15 (3.81)	0.5 (0.2)
	KS250100BB	1.02 (25.91)	0.90 (22.86)	0.19 (4.82)	0.15 (3.81)	0.5 (0.2)
NW40 (0.50 in. tubing)	KS400050BB	0.51 (12.95)	0.44 (11.18)	0.20 (5.08)	0.15 (3.81)	0.5 (0.2)
	KS400075BB	0.76 (19.30)	0.69 (17.53)	0.20 (5.08)	0.15 (3.81)	0.5 (0.2)
	KS400100BB	1.02 (25.91)	0.90 (22.86)	0.20 (5.08)	0.15 (3.81)	0.5 (0.2)
	KS400125BB	1.26 (32.00)	1.12 (28.45)	0.20 (5.08)	0.15 (3.81)	0.5 (0.2)
	KS400150BB	1.50 (38.10)	1.37 (34.80)	0.20 (5.08)	0.15 (3.81)	0.5 (0.2)
NW50 (.50 in. tubing)	KS500050BB	0.51 (12.95)	0.44 (11.18)	0.24 (6.10)	0.15 (3.81)	0.5 (0.2)
	KS500075BB	0.76 (19.30)	0.69 (17.53)	0.24 (6.10)	0.15 (3.81)	0.5 (0.2)
	KS500100BB	1.01 (25.65)	0.90 (22.86)	0.24 (6.10)	0.15 (3.81)	0.5 (0.2)
	KS500125BB	1.26 (32.00)	1.12 (28.45)	0.24 (6.10)	0.15 (3.81)	0.5 (0.2)
	KS500150BB	1.52 (38.62)	1.37 (34.80)	0.24 (6.10)	0.15 (3.81)	0.5 (0.2)
	KS500175BB	1.77 (44.96)	1.50 (38.10)	0.24 (6.10)	0.15 (3.81)	0.5 (0.2)
	KS500200BB	2.02 (51.31)	1.87 (47.50)	0.24 (6.10)	0.15 (3.81)	0.5 (0.2)

Unbored Stubs NW16 – NW50 (ISO)

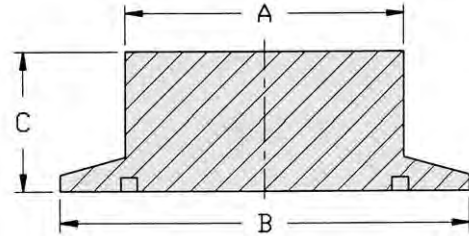

Specifications

- 304 stainless steel
- 6061 T6 aluminum
- Stub can be turned, bored, or tapped to fit

Ordering Information – Unbored Stubs (Stainless Steel)

Description	Part Number	A in. (mm)	B in. (mm)	C in. (mm)	Shipping Weight lbs (kg)
NW16	KS160000SUB	0.75 (19.05)	1.18 (29.97)	0.75 (19.05)	0.5 (0.2)
NW25	KS250000SUB	1.00 (25.40)	1.58 (40.13)	0.75 (19.05)	0.5 (0.2)
NW40	KS400000SUB	1.50 (38.10)	2.17 (55.12)	1.00 (25.40)	0.5 (0.2)
NW50	KS500000SUB	2.00 (50.80)	2.95 (74.93)	1.00 (25.40)	0.5 (0.2)

Ordering Information – Unbored Stubs (Aluminum)

Description	Part Number	A in. (mm)	B in. (mm)	C in. (mm)	Shipping Weight lbs (kg)
NW16	KS160000AUB	0.75 (19.05)	1.18 (29.97)	0.75 (19.05)	0.5 (0.2)
NW25	KS250000AUB	1.00 (25.40)	1.58 (40.13)	0.75 (19.05)	0.5 (0.2)
NW40	KS400000AUB	1.50 (38.10)	2.17 (55.12)	1.00 (25.40)	0.5 (0.2)
NW50	KS500000AUB	2.00 (50.80)	2.95 (74.93)	1.00 (25.40)	0.5 (0.2)

Klamps Flanges & Fittings

Weld Sockets NW10 – NW50 (ISO)

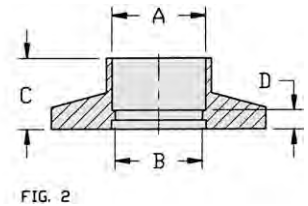
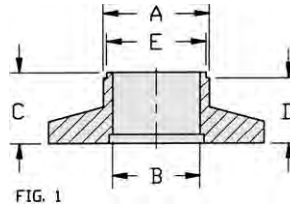

Specifications

- Self-aligning
- 304 stainless steel
- Socket weld
- Standard tube weld prep

Ordering Information

Description	Part Number	A in. (mm)	B in. (mm)	C in. (mm)	D in. (mm)	E in. (mm)	Weight lbs (kg)
NW10 (.50 in. tubing)	KS100050056SW	0.52 (13.21)	0.48 (12.19)	0.56 (14.20)	0.50 (12.70)	0.42 (10.67)	0.5 (0.2)
NW16 (.50 in. tubing)	KS160050050SW	0.51 (12.95)	0.45 (11.43)	0.50 (12.70)	0.25 (6.35)	N/A	0.5 (0.2)
NW16 (.75 in. tubing)	KS160075050SW	0.76 (19.30)	0.68 (17.27)	0.50 (12.70)	0.25 (6.35)	N/A	0.5 (0.2)
	KS160075056SW*	0.75 (19.05)	0.63 (16.00)	0.56 (14.20)	0.50 (12.70)	0.67 (17.02)	0.5 (0.2)
	KS160075059SW*	0.75 (19.05)	0.63 (16.00)	0.59 (14.99)	0.57 (14.50)	0.67 (17.02)	0.5 (0.2)
NW25 (1 in. tubing)	KS250100047SW	1.02 (25.92)	0.90 (23.00)	0.47 (12.00)	0.17 (4.30)	N/A	0.5 (0.2)
	KS250100050SW	1.02 (25.92)	0.87 (22.10)	0.50 (12.70)	0.25 (6.40)	N/A	0.5 (0.2)
	KS250100052SW	1.02 (25.92)	0.90 (23.00)	0.52 (13.20)	0.22 (5.60)	N/A	0.5 (0.2)
NW40 (1.5 in. tubing)	KS400150030SW	1.51 (38.35)	1.37 (34.80)	0.30 (7.60)	0.21 (5.30)	N/A	0.5 (0.2)
	KS400150040SW	1.51 (38.35)	1.37 (34.80)	0.40 (10.20)	0.31 (7.80)	N/A	0.5 (0.2)
	KS400150050SW	1.51 (38.35)	1.37 (34.80)	0.50 (12.70)	0.21 (5.30)	N/A	0.5 (0.2)
	KS40015005ASW	1.51 (38.35)	1.37 (34.80)	0.50 (12.70)	0.25 (6.40)	N/A	0.5 (0.2)
NW50 (2 in. tubing)	KS500200050SW	2.02 (51.31)	1.87 (47.50)	0.50 (12.70)	0.25 (6.40)	N/A	0.5 (0.2)
	KS500200062SW	2.02 (51.31)	1.87 (47.50)	0.62 (15.70)	0.22 (5.60)	N/A	0.5 (0.2)

* See Fig. 1; all other Part Numbers see Fig. 2.

NOTE • Custom sizes available on request

Components

Short Weld Stubs NW16 – NW50 (ISO)

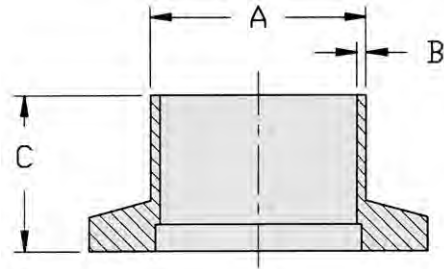

Specifications

- Butt weld
- Standard and metric tube sizes

Ordering Information – Short Weld Stubs (304 Stainless Steel)

Description	Part Number	Tube Size A in. (mm)	B in. (mm)	C in. (mm)	Shipping Weight lbs (kg)
NW16 (.50 in. tubing)	KS160050050	0.50 (12.70)	0.065 (1.65)	0.50 (12.70)	0.5 (0.2)
	KS160050057	0.50 (12.70)	0.035 (0.89)	0.57 (14.48)	0.5 (0.2)
NW16 (.75 in. tubing)	KS160075050	0.75 (19.05)	0.065 (1.65)	0.50 (12.70)	0.5 (0.2)
	KS160075057	0.75 (19.05)	0.035 (0.89)	0.57 (14.48)	0.5 (0.2)
	KS160078078	0.78 (19.81)	0.080 (2.03)	0.78 (19.81)	0.5 (0.2)
NW25 (1 in. tubing)	KS250100050	1.00 (25.40)	0.065 (1.65)	0.50 (12.70)	0.5 (0.2)
	KS250100057	1.00 (25.40)	0.049 (1.24)	0.57 (14.48)	0.5 (0.2)
	KS250110078	1.10 (27.94)	0.077 (1.95)	0.78 (19.81)	0.5 (0.2)
NW40 (1.25 in. tubing)	KS400125057	1.25 (31.75)	0.065 (1.65)	0.57 (14.48)	0.5 (0.2)
NW40 (1.50 in. tubing)	KS400150057	1.50 (38.10)	0.065 (1.65)	0.57 (14.48)	0.5 (0.2)
	KS400150075	1.50 (38.10)	0.065 (1.65)	0.75 (19.05)	0.5 (0.2)
	KS400175100	1.75 (44.45)	0.078 (1.98)	1.00 (25.40)	0.5 (0.2)
NW50 (2 in. tubing)	KS500200057	2.00 (50.80)	0.065 (1.65)	0.57 (14.48)	0.5 (0.2)
	KS500200075	2.00 (50.80)	0.065 (1.65)	0.75 (19.05)	0.5 (0.2)
	KS500220100	2.20 (55.88)	0.117 (2.97)	1.00 (25.40)	0.5 (0.2)

Ordering Information – Short Weld Stubs (6061 T6 Aluminum)

Description	Part Number	Tube Size A in. (mm)	B in. (mm)	C in. (mm)	Shipping Weight lbs (kg)
NW16 (.75 in. tubing)	KS160075050A	0.75 (19.05)	0.065 (1.65)	0.50 (12.70)	0.5 (0.2)
NW25 (1 in. tubing)	KS250100050A	1.00 (25.40)	0.065 (1.65)	0.50 (12.70)	0.5 (0.2)
NW40 (1.5 in. tubing)	KS400150075A	1.50 (38.10)	0.065 (1.65)	0.75 (19.05)	0.5 (0.2)
NW50 (2 in. tubing)	KS500200075A	2.00 (50.80)	0.065 (1.65)	0.75 (19.05)	0.5 (0.2)

Long Weld Stubs NW16 – NW50 (ISO)

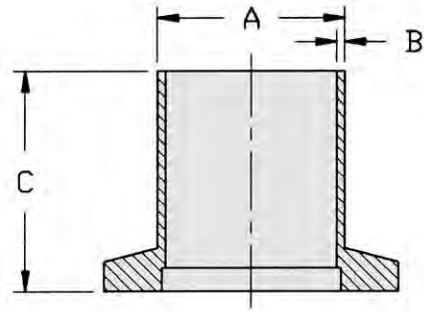

Specifications

- Butt weld
- Standard and metric tube sizes

Ordering Information – Long Weld Stubs (304 Stainless Steel)

Description	Part Number	Tube Size A in. (mm)	B in. (mm)	C in. (mm)	Shipping Weight lbs (kg)
NW16 (.50 in. tubing)	KS160050157	0.50 (12.70)	0.065 (1.65)	1.57 (40.0)	0.5 (0.2)
NW16 (.75 in. tubing)	KS160075115	0.75 (19.05)	0.035 (0.89)	1.15 (29.2)	0.5 (0.2)
	KS160075157	0.75 (19.05)	0.065 (1.65)	1.57 (40.0)	0.5 (0.2)
	KS160078197	0.78 (19.81)	0.078 (1.98)	1.97 (50.0)	0.5 (0.2)
NW25 (1 in. tubing)	KS250100143	1.00 (25.40)	0.049 (1.24)	1.43 (36.6)	0.5 (0.2)
	KS250100157	1.00 (25.40)	0.065 (1.65)	1.57 (40.0)	0.5 (0.2)
	KS250100203	1.00 (25.40)	0.065 (1.65)	2.03 (51.6)	0.5 (0.2)
	KS250110197	1.10 (27.94)	0.077 (1.95)	1.97 (50.0)	0.5 (0.2)
NW40 (1.50 in. tubing)	KS400150157	1.50 (38.10)	0.065 (1.65)	1.57 (40.0)	0.5 (0.2)
	KS400150175	1.50 (38.10)	0.065 (1.65)	1.75 (44.5)	0.5 (0.2)
	KS400150246	1.50 (38.10)	0.065 (1.65)	2.46 (62.5)	1.0 (0.5)
	KS400175197	1.75 (44.45)	0.083 (2.11)	1.97 (50.0)	0.5 (0.2)
NW50 (2 in. tubing)	KS500200157	2.00 (50.80)	0.065 (1.65)	1.57 (40.0)	0.5 (0.2)
	KS500200169	2.00 (50.80)	0.065 (1.65)	1.69 (42.9)	0.5 (0.2)
	KS500220217	2.20 (55.88)	0.117 (2.97)	2.17 (55.1)	0.5 (0.2)

Ordering Information – Long Weld Stubs (6061 T6 Aluminum)

Description	Part Number	Tube Size A in. (mm)	B in. (mm)	C in. (mm)	Shipping Weight lbs (kg)
NW16 (.50 in. tubing)	KS160050157A	0.50 (12.70)	0.065 (1.65)	1.57 (39.88)	0.5 (0.2)
NW16 (.75 in. tubing)	KS160075157A	0.75 (19.05)	0.065 (1.65)	1.57 (39.88)	0.5 (0.2)
NW25 (1 in. tubing)	KS250100157A	1.00 (25.40)	0.065 (1.65)	1.57 (39.88)	0.5 (0.2)
NW40 (1.5 in. tubing)	KS400150157A	1.50 (38.10)	0.083 (2.11)	1.57 (39.88)	0.5 (0.2)
NW50 (2 in. tubing)	KS500200157A	2.00 (50.80)	0.083 (2.11)	1.57 (39.88)	0.5 (0.2)

Components

Nipples NW16 – NW50 (ISO)

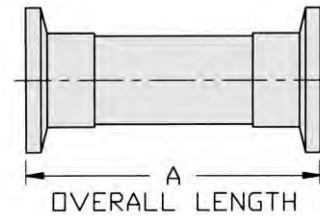

Specifications

- 304 stainless steel
- ISO-KF flanges
- Same flanges on both ports
- Full penetration vacuum welds
- Custom lengths available

Ordering Information

Description	Part Number	A in. (mm)	Shipping Weight lbs (kg)
NW16	KNF00750230	2.30 (58.42)	1.0 (0.5)
	KNF00750315	3.15 (80.01)	1.0 (0.5)
	KNF00750645	6.45 (163.83)	2.0 (0.9)
	KNF00751260	12.60 (320.04)	3.0 (1.4)
NW25	KNF01000394	3.94 (100.08)	1.0 (0.5)
	KNF01000406	4.06 (103.12)	1.0 (0.5)
	KNF01000408	4.08 (103.63)	1.0 (0.5)
	KNF01000803	8.03 (203.96)	2.0 (0.9)
	KNF01001260	12.60 (320.04)	3.0 (1.4)
NW40	KNF01500480	4.80 (121.92)	1.0 (0.5)
	KNF01500493	4.93 (125.22)	1.0 (0.5)
	KNF01500512	5.12 (130.05)	1.0 (0.5)
	KNF01501039	10.39 (263.91)	4.0 (1.8)
	KNF01501260	12.60 (320.04)	4.0 (1.8)
NW50	KNF02000551	5.51 (139.95)	1.0 (0.5)
	KNF02000630	6.30 (160.02)	1.0 (0.5)
	KNF02000643	6.43 (163.32)	1.0 (0.5)
	KNF02001118	11.18 (283.97)	4.0 (1.8)
	KNF02001260	12.60 (320.04)	4.0 (1.8)

Klamps Flanges & Fittings

Elbows (90°) NW16 – NW50 (ISO)

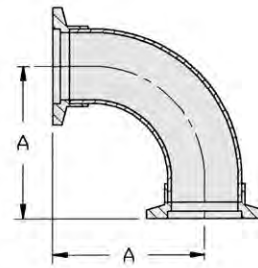

FIG. 1

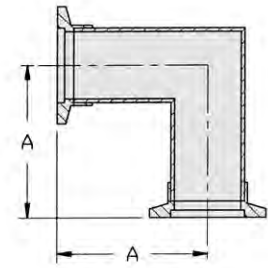

FIG. 2

Specifications

- 304 stainless steel
- ISO-KF Flanges
- Same flanges on both ports
- Full penetration vacuum welds
- Custom configurations available

Ordering Information

Description	Part Number	A in. (mm)	Fig. Number	Shipping Weight lbs (kg)
NW16	KE00750150	1.50 (38.10)	1	1.0 (0.5)
	KE00750157	1.57 (39.88)	1	1.0 (0.5)
NW25	KE01000197	1.97 (50.04)	1	1.0 (0.5)
	KE01000204	2.04 (51.82)	1	1.0 (0.5)
NW40	KE01500246	2.46 (62.48)	1	2.0 (0.9)
	KE01500256	2.56 (65.02)	1	2.0 (0.9)
NW50	KE02000276	2.76 (70.10)	2	2.0 (0.9)
	KE02000321	3.21 (81.53)	2	2.0 (0.9)

Components

Tees NW16 – NW50 (ISO)

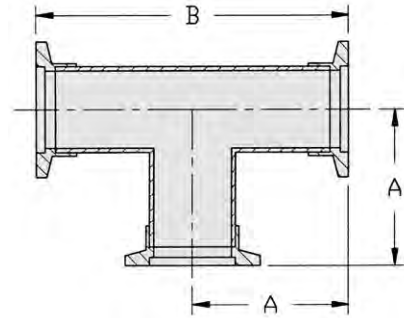

Specifications

- 304 stainless steel
- ISO-KF flanges
- Same flanges on all ports
- Full penetration vacuum welds

Ordering Information

Description	Part Number	A in. (mm)	B in. (mm)	Shipping Weight lbs (kg)
NW16	KT00750150	1.50 (38.10)	3.00 (76.20)	1.5 (0.7)
	KT00750157	1.57 (39.88)	3.15 (80.01)	1.5 (0.7)
NW25	KT01000197	1.97 (50.04)	3.94 (100.08)	2.0 (0.9)
	KT01000204	2.04 (51.82)	4.08 (103.63)	2.0 (0.9)
NW40	KT01500246	2.46 (62.48)	4.92 (124.97)	2.0 (0.9)
	KT01500256	2.56 (65.02)	5.12 (130.05)	2.0 (0.9)
NW50	KT02000276	2.76 (70.10)	5.52 (140.21)	3.0 (1.4)
	KT02000321	3.21 (81.53)	6.42 (163.07)	3.0 (1.4)

Klamps Flanges & Fittings

4-Way Crosses NW16 – NW50 (ISO)

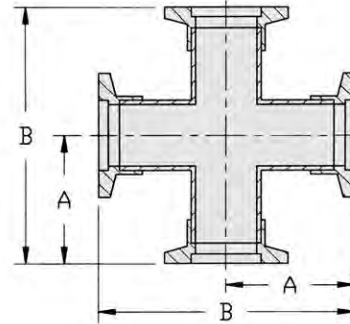

Specifications

- 304 stainless steel
- ISO-KF flanges
- Same flanges on all ports
- Full penetration vacuum welds
- Custom configurations available for 5-Way and 6-Way Crosses

Ordering Information

Description	Part Number	A in. (mm)	B in. (mm)	Shipping Weight lbs (kg)
NW16	KC00750150	1.50 (38.10)	3.00 (76.20)	1.5 (0.7)
	KC00750157	1.57 (39.88)	3.14 (80.01)	1.5 (0.7)
NW25	KC01000197	1.97 (50.04)	3.94 (100.08)	2.0 (0.9)
	KC01000204	2.04 (51.82)	4.08 (103.63)	2.0 (0.9)
NW40	KC01500246	2.46 (62.48)	4.92 (124.97)	3.0 (1.4)
	KC01500256	2.56 (65.02)	5.12 (130.05)	3.0 (1.4)
NW50	KC02000276	2.76 (70.10)	5.52 (140.21)	3.0 (1.4)
	KC02000321	3.21 (81.53)	6.44 (163.60)	3.0 (1.4)

Straight Reducers NW16 – NW50 (ISO)

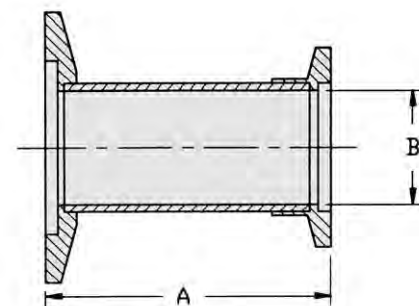

Specifications

- 304 stainless steel
- Straight through

Ordering Information

Description	Part Number	A in. (mm)	B in. (mm)	Shipping Weight lbs (kg)
NW16 to NW25	KRS1625	1.57 (39.88)	0.69 (17.53)	1.0 (0.5)
NW16 to NW40	KRS1640	1.57 (39.88)	0.69 (17.53)	1.0 (0.5)
NW16 to NW50	KRS1650	1.57 (39.88)	0.69 (17.53)	1.0 (0.5)
NW25 to NW40	KRS2540	1.57 (39.88)	0.90 (22.86)	1.0 (0.5)
NW25 to NW50	KRS2550	1.57 (39.88)	0.90 (22.86)	1.0 (0.5)
NW40 to NW50	KRS4050	1.57 (39.88)	1.37 (34.80)	1.0 (0.5)

Conical Reducers NW16 – NW50 (ISO)

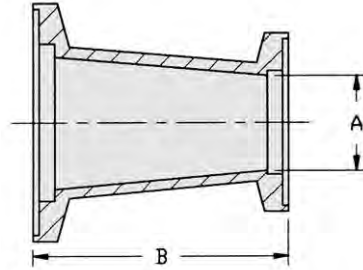

Specifications

- 304 stainless steel
- 6061 T6 aluminum

Ordering Information – Conical Reducers (304 Stainless Steel)

Description	Part Number	A in. (mm)	B in. (mm)	Shipping Weight lbs (kg)
NW16 to NW25	KRC1625S	0.62 (15.75)	1.65 (41.91)	1.0 (0.5)
NW16 to NW40	KRC1640S	0.62 (15.75)	1.65 (41.91)	1.0 (0.5)
NW16 to NW50	KRC1650S	0.62 (15.75)	1.65 (41.91)	1.0 (0.5)
NW25 to NW40	KRC2540S	0.87 (22.10)	1.65 (41.91)	1.0 (0.5)
NW25 to NW50	KRC2550S	0.87 (22.10)	1.65 (41.91)	1.0 (0.5)
NW40 to NW50	KRC4050S	1.37 (34.80)	1.65 (41.91)	1.0 (0.5)

Ordering Information – Conical Reducers (6061 T6 Aluminum)

Description	Part Number	A in. (mm)	B in. (mm)	Shipping Weight lbs (kg)
NW16 to NW25	KRC1625A	0.62 (15.75)	1.65 (41.91)	1.0 (0.5)
NW16 to NW40	KRC1640A	0.62 (15.75)	1.65 (41.91)	1.0 (0.5)
NW16 to NW50	KRC1650A	0.62 (15.75)	1.65 (41.91)	1.0 (0.5)
NW25 to NW40	KRC2540A	0.87 (22.10)	1.65 (41.91)	1.0 (0.5)
NW25 to NW50	KRC2550A	0.87 (22.10)	1.65 (41.91)	1.0 (0.5)
NW40 to NW50	KRC4050A	1.37 (34.80)	1.65 (41.91)	1.0 (0.5)

Klamps Flanges & Fittings

KF to CFF Adapters

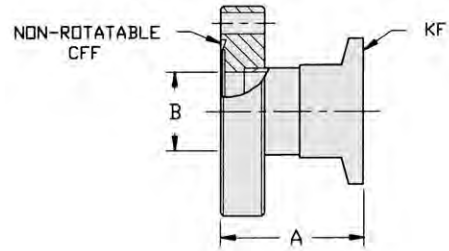

Ordering Information

CFF Size	Part Number	CFF OD	KF Flange		Overall Length A in. (mm)	Tube ID B in. (mm)	Shipping Weight lbs (kg)
			NW	Size OD			
1 1/8 in.	FA0133NW16S	1.33	NW16	1.18	1.57 (39.88)	0.68 (17.27)	1.0 (0.5)
	FA0133NW16	1.33	NW16	1.18	2.00 (50.80)	0.68 (17.27)	1.0 (0.5)
	FA0133NW16L	1.33	NW16	1.18	2.07 (52.70)	0.68 (17.27)	1.0 (0.5)
	FA0133NW25	1.33	NW25	1.57	2.00 (50.80)	0.68 (17.27)	1.5 (0.7)
2 3/4 in.	FA0275NW16S	2.73	NW16	1.18	1.78 (45.21)	0.68 (17.27)	1.5 (0.7)
	FA0275NW16	2.73	NW16	1.18	2.00 (50.80)	0.68 (17.27)	1.5 (0.7)
	FA0275NW16L	2.73	NW16	1.18	2.36 (59.94)	0.68 (17.27)	1.5 (0.7)
	FA0275NW25S	2.73	NW25	1.57	1.78 (45.21)	0.87 (22.10)	1.5 (0.7)
	FA0275NW25	2.73	NW25	1.57	2.00 (50.80)	0.87 (22.10)	1.5 (0.7)
	FA0275NW25L	2.73	NW25	1.57	2.36 (59.94)	0.87 (22.10)	1.5 (0.7)
	FA0275NW40S	2.73	NW40	2.16	1.78 (45.21)	1.37 (34.80)	2.0 (0.9)
	FA0275NW40	2.73	NW40	2.16	2.00 (50.80)	1.37 (34.80)	2.0 (0.9)
4 1/2 in.	FA0275NW40L	2.73	NW40	2.16	2.55 (64.77)	1.37 (34.80)	2.0 (0.9)
	FA0450NW40	4.47	NW40	2.16	2.00 (50.80)	1.37 (34.80)	3.0 (1.4)
	FA0450NW50L	4.47	NW50	2.95	2.00 (50.80)	1.87 (47.50)	3.0 (1.4)
	FA0450NW50	4.47	NW50	2.95	1.95 (49.53)	1.87 (34.80)	3.0 (1.4)

Components

Accessories

Size	Gasket	Description	Part Number	Qty/Pkg	Shipping Weight lbs (kg)
1 1/8 in.	Copper	10-pack, individually sealed	FG0133CI	10	1.0 (0.5)
	Viton	5-pack	FG0133VU	5	0.5 (0.2)
2 1/8 in.	Copper	10-pack, individually sealed	FG0212CI	10	1.0 (0.5)
	Viton	5-pack	FG0212VU	5	0.5 (0.2)
2 3/4 in.	Copper	10-pack, individually sealed	FG0275CI	10	1.0 (0.5)
	Viton	5-pack	FG0275VU	5	0.5 (0.2)
3 3/8 in.	Copper	10-pack, individually sealed	FG0338CI	10	1.0 (0.5)
	Viton	1-pack	FG0338VU	1	0.5 (0.2)
4 1/2 in.	Copper	10-pack, individually sealed	FG0450CI	10	2.0 (0.9)
	Viton	1-pack	FG0450VU	1	0.5 (0.2)

Accessories

Size	Nut and Bolt Sets	Hex Head Part Number	12-Point Bolt Part Number	Qty/Pkg	Shipping Weight lbs (kg)
1 1/8 in.	Clear hole flanges	N/A	FB0133C**	25	0.5 (0.2)
	Tapped hole flanges	N/A	FB0133T**	25	0.5 (0.2)
2 1/8 in.	Clear hole flanges	FB0275C06	FB0275C12	25	1.0 (0.5)
	Tapped hole flanges	FB0275T06	FB0275T12	25	1.0 (0.5)
2 3/4 in.	Clear hole flanges	FB0275C06	FB0275C12	25	1.0 (0.5)
	Tapped hole flanges	FB0275T06	FB0275T12	25	1.0 (0.5)
3 3/8 in.	Clear hole flanges	FB0338C06	FB0338C12	25	2.0 (0.9)
	Tapped hole flanges	FB0450T06	FB0450T12	25	2.0 (0.9)
4 1/2 in.	Clear hole flanges	FB0450C06	FB0450C12	25	2.0 (0.9)
	Tapped hole flanges	FB0450T06	FB0450T12	25	2.0 (0.9)

* Includes nuts, washers, and bolts

** Only available in Socket Head

Accessories

Size	Description	Part Number	Qty/Pkg	Shipping Weight lbs (kg)
NW16	Viton Centering Ring	KC16SV	1	0.5 (0.2)
NW25	Viton Centering Ring	KC25SV	1	0.5 (0.2)
NW40	Viton Centering Ring	KC40SV	1	0.5 (0.2)
NW50	Viton Centering Ring	KC50SV	1	0.5 (0.2)
NW16	KF Clamp	KQ16AR	1	0.5 (0.2)
NW25	KF Clamp	KQ25AR	1	0.5 (0.2)
NW40	KF Clamp	KQ40AR	1	1.0 (0.5)
NW50	KF Clamp	KQ50AR	1	1.0 (0.5)

NOTE * Custom adapters available on request

Klamps Flanges & Fittings

Stainless Steel Male Pipe Adapters NW16 – NW50 (ISO)

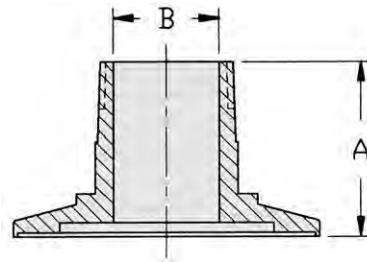

Specifications

- 304 stainless steel
- Male pipe threads
- Wrench flats on shank

Ordering Information

Description	Part Number	A in. (mm)	B in. (mm)	Shipping Weight lbs (kg)	
NW16	1/8 NPT	KAMP160125S	1.47 (37.34)	0.19 (4.83)	1.0 (0.5)
	1/4 NPT	KAMP160250S	1.47 (37.34)	0.28 (7.11)	1.0 (0.5)
	3/8 NPT	KAMP160375S	1.47 (37.34)	0.42 (10.70)	1.0 (0.5)
	1/2 NPT	KAMP160500S	1.69 (42.93)	0.58 (14.73)	1.0 (0.5)
NW25	1/8 NPT	KAMP250125S	1.47 (37.34)	0.19 (4.83)	1.0 (0.5)
	1/4 NPT	KAMP250250S	1.47 (37.34)	0.28 (7.11)	1.0 (0.5)
	3/8 NPT	KAMP250375S	1.47 (37.34)	0.42 (10.70)	1.0 (0.5)
	1/2 NPT	KAMP250500S	1.69 (42.93)	0.58 (14.73)	1.0 (0.5)
	3/4 NPT	KAMP250750S	1.69 (42.93)	0.78 (19.81)	1.0 (0.5)
NW40	1/8 NPT	KAMP400125S	1.47 (37.34)	0.19 (4.83)	1.0 (0.5)
	1/4 NPT	KAMP400250S	1.47 (37.34)	0.28 (7.11)	1.0 (0.5)
	3/8 NPT	KAMP400375S	1.47 (37.34)	0.42 (10.70)	1.0 (0.5)
	1/2 NPT	KAMP400500S	1.69 (42.93)	0.58 (14.73)	1.0 (0.5)
	3/4 NPT	KAMP400750S	1.69 (42.93)	0.78 (19.81)	1.0 (0.5)
	1NPT	KAMP401000S	1.69 (42.93)	1.02 (25.91)	1.0 (0.5)

Components

Aluminum Male Pipe Adapters NW16 – NW50 (ISO)

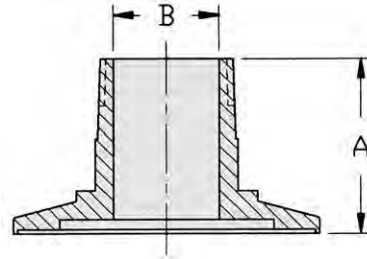

Specifications

- 6061 T6 aluminum
- Male pipe threads
- Wrench flats on shank

Ordering Information

Description	Part Number	A in. (mm)	B in. (mm)	Shipping Weight lbs (kg)	
NW16	1/8 NPT	KAMP160125A	1.47 (37.34)	0.19 (4.83)	1.0 (0.5)
	1/4 NPT	KAMP160250A	1.47 (37.34)	0.28 (7.11)	1.0 (0.5)
	3/8 NPT	KAMP160375A	1.47 (37.34)	0.42 (10.70)	1.0 (0.5)
	1/2 NPT	KAMP160500A	1.69 (42.93)	0.58 (14.73)	1.0 (0.5)
NW25	1/8 NPT	KAMP250125A	1.47 (37.34)	0.19 (4.83)	1.0 (0.5)
	1/4 NPT	KAMP250250A	1.47 (37.34)	0.28 (7.11)	1.0 (0.5)
	3/8 NPT	KAMP250375A	1.47 (37.34)	0.42 (10.70)	1.0 (0.5)
	1/2 NPT	KAMP250500A	1.69 (42.93)	0.58 (14.73)	1.0 (0.5)
	3/4 NPT	KAMP250750A	1.69 (42.93)	0.78 (19.81)	1.0 (0.5)
NW40	1/8 NPT	KAMP400125A	1.47 (37.34)	0.19 (4.83)	1.0 (0.5)
	1/4 NPT	KAMP400250A	1.47 (37.34)	0.28 (7.11)	1.0 (0.5)
	3/8 NPT	KAMP400375A	1.47 (37.34)	0.42 (10.70)	1.0 (0.5)
	1/2 NPT	KAMP400500A	1.69 (42.93)	0.58 (14.73)	1.0 (0.5)
	3/4 NPT	KAMP400750A	1.69 (42.93)	0.78 (19.81)	1.0 (0.5)
	1NPT	KAMP401000A	1.69 (42.93)	1.02 (25.91)	1.0 (0.5)

Klamps Flanges & Fittings

Stainless Steel Female Pipe Adapters NW16 – NW50 (ISO)

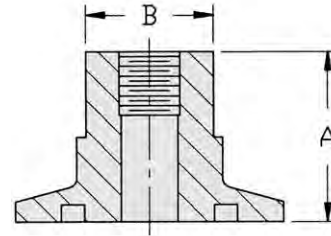

Specifications

- 304 stainless steel
- Female pipe threads
- Wrench flats on shank

Ordering Information

Description	Part Number	A in. (mm)	B in. (mm)	Shipping Weight lbs (kg)	
NW16	1/8 NPT	KAFP160125S	1.04 (26.42)	0.75 (19.05)	1.0 (0.5)
	1/4 NPT	KAFP160250S	1.04 (26.42)	0.75 (19.05)	1.0 (0.5)
	3/8 NPT	KAFP160375S	1.04 (26.42)	0.88 (22.23)	1.0 (0.5)
NW25	1/8 NPT	KAFP250125S	1.04 (26.42)	0.75 (19.05)	1.0 (0.5)
	1/4 NPT	KAFP250250S	1.04 (26.42)	0.75 (19.05)	1.0 (0.5)
	3/8 NPT	KAFP250375S	1.04 (26.42)	0.88 (22.23)	1.0 (0.5)
	1/2 NPT	KAFP250500S	1.04 (26.42)	1.13 (28.58)	1.0 (0.5)
NW40	1/8 NPT	KAFP400125S	1.04 (26.42)	0.75 (19.05)	1.0 (0.5)
	1/4 NPT	KAFP400250S	1.04 (26.42)	0.75 (19.05)	1.0 (0.5)
	3/8 NPT	KAFP400375S	1.04 (26.42)	0.88 (22.23)	1.0 (0.5)
	1/2 NPT	KAFP400500S	1.65 (41.91)	1.13 (28.58)	1.0 (0.5)
	3/4 NPT	KAFP400750S	1.65 (41.91)	1.25 (31.75)	1.0 (0.5)
	1NPT	KAFP401000S	1.65 (41.91)	1.56 (39.67)	1.0 (0.5)

Components

Aluminum Female Pipe Adapters NW16 – NW50 (ISO)

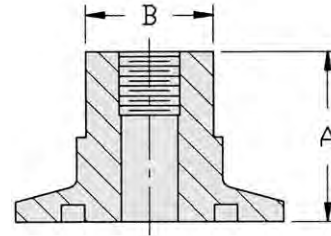

Specifications

- 6061 T6 aluminum
- Female pipe threads
- Wrench flats on shank

Ordering Information

Description	Part Number	A in. (mm)	B in. (mm)	Shipping Weight lbs (kg)	
NW16	1/8 NPT	KAFP160125A	1.04 (26.42)	0.75 (19.05)	1.0 (0.5)
	1/4 NPT	KAFP160250A	1.04 (26.42)	0.75 (19.05)	1.0 (0.5)
	3/8 NPT	KAFP160375A	1.04 (26.42)	0.88 (22.23)	1.0 (0.5)
NW25	1/8 NPT	KAFP250125A	1.04 (26.42)	0.75 (19.05)	1.0 (0.5)
	1/4 NPT	KAFP250250A	1.04 (26.42)	0.75 (19.05)	1.0 (0.5)
	3/8 NPT	KAFP250375A	1.04 (26.42)	0.88 (22.23)	1.0 (0.5)
	1/2 NPT	KAFP250500A	1.04 (26.42)	1.13 (28.58)	1.0 (0.5)
NW40	1/8 NPT	KAFP400125A	1.04 (26.42)	0.75 (19.05)	1.0 (0.5)
	1/4 NPT	KAFP400250A	1.04 (26.42)	0.75 (19.05)	1.0 (0.5)
	3/8 NPT	KAFP400375A	1.04 (26.42)	0.88 (22.23)	1.0 (0.5)
	1/2 NPT	KAFP400500A	1.65 (41.91)	1.13 (28.58)	1.0 (0.5)
	3/4 NPT	KAFP400750A	1.65 (41.91)	1.25 (31.75)	1.0 (0.5)
1NPT	KAFP401000A	1.65 (41.91)	1.56 (39.67)	1.0 (0.5)	

Klamps Flanges & Fittings

Flexible Couplings (Non-Braided)

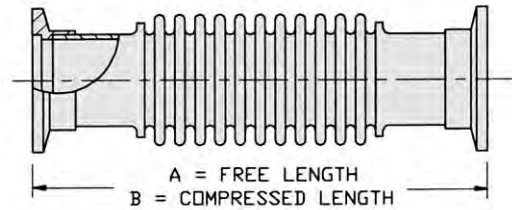
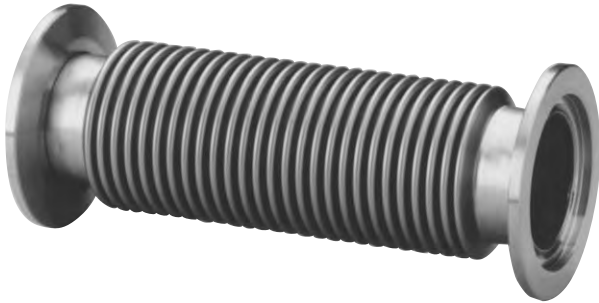

Specifications

- Stainless steel
- Full penetration vacuum weld
- Custom lengths available

Ordering Information

Flange Size	Part Number	Length		Static Bend Radius in. (mm)	Bellows Wall Thickness in.	Nominal ID in. (mm)	Shipping Weight lbs (kg)
		A in. (mm)	B in. (mm)				
NW16	KL00750315	3.2 (81)	2.9 (75)	3.0 (76)	0.006	0.75 (19.1)	1.0 (0.5)
	KL00750394	3.9 (100)	3.7 (93)	3.0 (76)	0.006	0.75 (19.1)	1.0 (0.5)
	KL00750984	9.8 (250)	9.0 (228)	3.0 (76)	0.006	0.75 (19.1)	1.5 (0.7)
	KL00751969	19.7 (500)	17.8 (453)	1.3 (33)	0.008	0.75 (19.1)	3.0 (1.4)
	KL00753940	39.4 (1000)	35.6 (903)	1.3 (33)	0.008	0.75 (19.1)	4.0 (1.8)
	KL00754800	48.0 (1219)	43.3 (1100)	1.3 (33)	0.008	0.75 (19.1)	5.0 (2.3)
NW25	KL01000394	3.9 (100)	3.6 (92)	4.0 (102)	0.006	1.00 (25.4)	1.0 (0.5)
	KL01000984	9.8 (250)	8.9 (227)	4.0 (102)	0.006	1.00 (25.4)	1.0 (0.5)
	KL01001969	19.7 (500)	17.8 (452)	1.5 (38)	0.008	1.00 (25.4)	3.0 (1.4)
	KL01002400	24.0 (609)	21.7 (551)	1.5 (38)	0.008	1.00 (25.4)	3.0 (1.4)
	KL01003940	39.4 (1000)	35.5 (903)	1.5 (38)	0.008	1.00 (25.4)	4.0 (1.8)
	KL01004800	48.0 (1219)	43.3 (1100)	1.5 (38)	0.008	1.00 (25.4)	5.0 (2.3)
NW40	KL01500394	3.9 (100)	3.6 (92)	6.0 (152)	0.006	1.38 (35.1)	1.0 (0.5)
	KL01500512	5.1 (130)	4.7 (119)	6.0 (152)	0.006	1.50 (38.1)	1.5 (0.7)
	KL01500984	9.8 (250)	8.9 (227)	6.0 (152)	0.006	1.50 (38.1)	2.0 (0.9)
	KL01501200	12.0 (305)	10.9 (276)	6.0 (152)	0.006	1.50 (38.1)	2.5 (1.1)
	KL01501969	19.7 (500)	17.8 (452)	2.2 (56)	0.010	1.50 (38.1)	3.0 (1.4)
	KL01502400	24.0 (609)	21.7 (551)	2.2 (56)	0.010	1.50 (38.1)	3.5 (1.6)
	KL01503940	39.4 (1000)	35.5 (903)	2.2 (56)	0.010	1.50 (38.1)	4.0 (1.8)
	KL01504800	48.0 (1219)	43.3 (1100)	2.2 (56)	0.010	1.50 (38.1)	5.0 (2.3)
NW50	KL02000394	3.9 (100)	3.7 (93)	6.0 (152)	0.006	1.88 (47.8)	1.0 (0.5)
	KL02000551	5.5 (140)	5.1 (129)	7.5 (191)	0.006	2.00 (50.8)	1.5 (0.7)
	KL02000984	9.8 (250)	9.0 (228)	7.5 (191)	0.006	2.00 (50.8)	2.0 (0.9)
	KL02001969	19.7 (500)	17.8 (453)	2.6 (66)	0.012	2.00 (50.8)	3.0 (1.4)
	KL02003940	39.4 (1000)	35.6 (903)	2.6 (66)	0.012	2.00 (50.8)	4.0 (1.8)
	KL02004800	48.0 (1219)	43.3 (1100)	2.6 (66)	0.012	2.00 (50.8)	5.0 (2.3)

Components

Flexible Couplings (Braided)

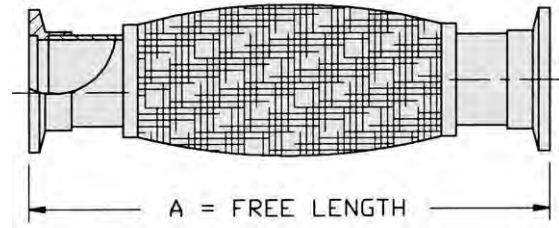
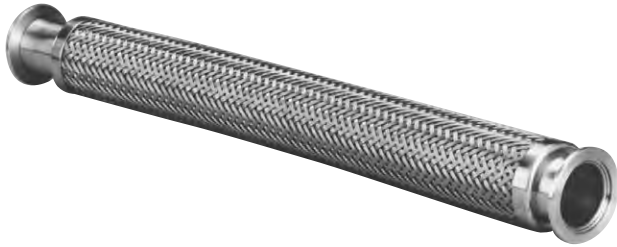

Specifications

- Stainless steel
- Braided sheathing
- Full penetration vacuum weld
- Custom lengths available

Ordering Information

Flange Size	Part Number	Length Free A in. (mm)	Static Bend Radius in. (mm)	Bellows Wall Thickness in.	Nominal ID in. (mm)	Shipping Weight lbs (kg)
NW16	KLB00751200	12.0 (305)	2.1 (53)	0.008	0.75 (19.1)	2.0 (0.9)
	KLB00751850	18.5 (470)	2.1 (53)	0.008	0.75 (19.1)	2.0 (0.9)
	KLB00752400	24.0 (610)	2.1 (53)	0.008	0.75 (19.1)	3.0 (1.4)
	KLB00753600	36.0 (914)	2.1 (53)	0.008	0.75 (19.1)	4.0 (1.8)
	KLB00754000	40.0 (1016)	2.1 (53)	0.008	0.75 (19.1)	5.0 (2.3)
	KLB00754800	48.0 (1219)	2.1 (53)	0.008	0.75 (19.1)	5.0 (2.3)
NW25	KLB01001000	10.0 (254)	2.5 (64)	0.008	1.00 (25.4)	3.0 (1.4)
	KLB01001200	12.0 (305)	2.5 (64)	0.008	1.00 (25.4)	3.0 (1.4)
	KLB01001850	18.5 (470)	2.5 (64)	0.008	1.00 (25.4)	3.0 (1.4)
	KLB01002000	20.0 (508)	2.5 (64)	0.008	1.00 (25.4)	3.0 (1.4)
	KLB01002400	24.0 (610)	2.5 (64)	0.008	1.00 (25.4)	3.0 (1.4)
	KLB01003600	36.0 (914)	2.5 (64)	0.008	1.00 (25.4)	4.0 (1.8)
	KLB01004000	40.0 (1016)	2.5 (64)	0.008	1.00 (25.4)	5.0 (2.3)
	KLB01004800	48.0 (1219)	2.5 (64)	0.008	1.00 (25.4)	5.0 (2.3)
NW40	KLB01501000	10.0 (254)	3.9 (99)	0.010	1.50 (38.1)	4.0 (1.8)
	KLB01501200	12.0 (305)	3.9 (99)	0.010	1.50 (38.1)	4.0 (1.8)
	KLB01501850	18.5 (470)	3.9 (99)	0.010	1.50 (38.1)	4.0 (1.8)
	KLB01502000	20.0 (508)	3.9 (99)	0.010	1.50 (38.1)	4.0 (1.8)
	KLB01502400	24.0 (610)	3.9 (99)	0.010	1.50 (38.1)	4.5 (2.1)
	KLB01503600	36.0 (914)	3.9 (99)	0.010	1.50 (38.1)	4.5 (2.1)
	KLB01504000	40.0 (1016)	3.9 (99)	0.010	1.50 (38.1)	5.0 (2.3)
	KLB01504800	48.0 (1219)	3.9 (99)	0.010	1.50 (38.1)	5.0 (2.3)
	NW50	KLB02002400	24.0 (610)	4.7 (120)	0.012	2.00 (50.8)
KLB02003600		36.0 (914)	4.7 (120)	0.012	2.00 (50.8)	7.0 (3.2)
KLB02004000		40.0 (1016)	4.7 (120)	0.012	2.00 (50.8)	7.0 (3.2)
KLB02004800		48.0 (1219)	4.7 (120)	0.012	2.00 (50.8)	8.0 (3.6)

KF to Compression Port Adapters

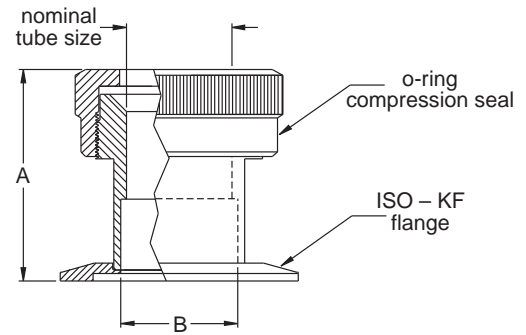

Figure 1

Specifications

- 304 stainless steel
- Knurled nut for hand-tightening
- ISO-KF Flanges
- Use for standard inch size tubulation

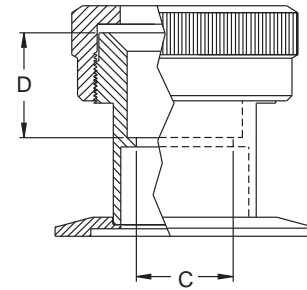

Figure 2

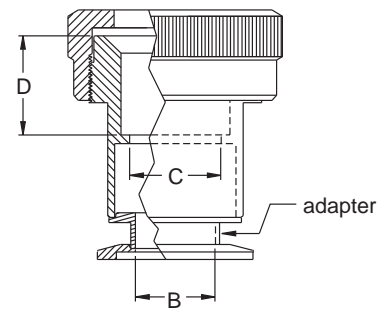

Figure 3

Components

Ordering Information

Flange Size	Part Number	Nominal Tube Size	Length		Bore		ID C in. (mm)	Tube Stop D in. (mm)	Fig.	Weight lbs (kg)
			A in. (mm)	B in. (mm)	B in. (mm)	B in. (mm)				
NW16	KCP160062	1/16 in.	1.65 (41.91)	0.63 (16.00)	0.63 (16.00)	0.63 (16.00)	—	—	1	1.0 (0.5)
	KCP160125	1/8 in.	1.65 (41.91)	0.63 (16.00)	0.63 (16.00)	0.63 (16.00)	—	—	1	1.0 (0.5)
	KCP160190	3/16 in.	1.65 (41.91)	0.63 (16.00)	0.63 (16.00)	0.63 (16.00)	—	—	1	1.0 (0.5)
	KCP160250	1/4 in.	1.65 (41.91)	0.63 (16.00)	0.63 (16.00)	0.63 (16.00)	—	—	1	1.0 (0.5)
	KCP160312	5/16 in.	1.65 (41.91)	0.63 (16.00)	0.63 (16.00)	0.63 (16.00)	—	—	1	1.0 (0.5)
	KCP160375	3/8 in.	1.65 (41.91)	0.63 (16.00)	0.63 (16.00)	0.63 (16.00)	—	—	1	1.0 (0.5)
	KCP160500	1/2 in.	1.65 (41.91)	0.63 (16.00)	0.63 (16.00)	0.63 (16.00)	—	—	1	1.0 (0.5)
	KCP160625	5/8 in.	1.65 (41.91)	0.63 (16.00)	0.63 (16.00)	0.63 (16.00)	—	—	1	1.0 (0.5)
NW25	KCP250062	1/16 in.	1.65 (41.91)	0.63 (16.00)	0.63 (16.00)	0.63 (16.00)	—	—	1	1.0 (0.5)
	KCP250125	1/8 in.	1.65 (41.91)	0.63 (16.00)	0.63 (16.00)	0.63 (16.00)	—	—	1	1.0 (0.5)
	KCP250190	3/16 in.	1.65 (41.91)	0.63 (16.00)	0.63 (16.00)	0.63 (16.00)	—	—	1	1.0 (0.5)
	KCP250250	1/4 in.	1.65 (41.91)	0.63 (16.00)	0.63 (16.00)	0.63 (16.00)	—	—	1	1.0 (0.5)
	KCP250312	5/16 in.	1.65 (41.91)	0.63 (16.00)	0.63 (16.00)	0.63 (16.00)	—	—	1	1.0 (0.5)
	KCP250375	3/8 in.	1.65 (41.91)	0.63 (16.00)	0.63 (16.00)	0.63 (16.00)	—	—	1	1.0 (0.5)
	KCP250500	1/2 in.	1.65 (41.91)	0.63 (16.00)	0.63 (16.00)	0.63 (16.00)	—	—	1	1.0 (0.5)
	KCP250625	5/8 in.	1.65 (41.91)	0.63 (16.00)	0.63 (16.00)	0.63 (16.00)	—	—	1	1.0 (0.5)
KCP250750	3/4 in.	2.37 (60.20)	0.90 (22.86)	0.90 (22.86)	0.90 (22.86)	0.63 (16.0)	1.13 (28.7)	3	1.0 (0.5)	
NW40	KCP400062	1/16 in.	1.65 (41.91)	0.63 (16.00)	0.63 (16.00)	0.63 (16.00)	—	—	1	2.0 (0.9)
	KCP400125	1/8 in.	1.65 (41.91)	0.63 (16.00)	0.63 (16.00)	0.63 (16.00)	—	—	1	2.0 (0.9)
	KCP400190	3/16 in.	1.65 (41.91)	0.63 (16.00)	0.63 (16.00)	0.63 (16.00)	—	—	1	2.0 (0.9)
	KCP400250	1/4 in.	1.65 (41.91)	0.63 (16.00)	0.63 (16.00)	0.63 (16.00)	—	—	1	2.0 (0.9)
	KCP400312	5/16 in.	1.65 (41.91)	0.63 (16.00)	0.63 (16.00)	0.63 (16.00)	—	—	1	2.0 (0.9)
	KCP400375	3/8 in.	1.65 (41.91)	0.63 (16.00)	0.63 (16.00)	0.63 (16.00)	—	—	1	2.0 (0.9)
	KCP400500	1/2 in.	1.65 (41.91)	0.63 (16.00)	0.63 (16.00)	0.63 (16.00)	—	—	1	2.0 (0.9)
	KCP400625	5/8 in.	1.65 (41.91)	0.63 (16.00)	0.63 (16.00)	0.63 (16.00)	—	—	1	2.0 (0.9)
	KCP400750	3/4 in.	2.02 (51.31)	1.38 (35.05)	1.38 (35.05)	1.38 (35.05)	—	—	1	2.0 (0.9)
	KCP400880	7/8 in.	2.02 (51.31)	1.38 (35.05)	1.38 (35.05)	1.38 (35.05)	—	—	1	2.0 (0.9)
	KCP401000	1 in.	2.02 (51.31)	1.38 (35.05)	1.38 (35.05)	1.38 (35.05)	0.88 (22.4)	1.13 (28.7)	2	2.0 (0.9)
	KCP401125	1 1/8 in.	2.02 (51.31)	1.38 (35.05)	1.38 (35.05)	1.38 (35.05)	—	—	1	2.0 (0.9)
	KCP401250	1 1/4 in.	2.02 (51.31)	1.38 (35.05)	1.38 (35.05)	1.38 (35.05)	—	—	1	2.0 (0.9)

NOTE • Custom configurations available on request

Klamps Flanges & Fittings

Adapters: KF to Swagelok

NOTE • KF flanges are 304L stainless steel



Ordering Information

Flange Size	Tube Size	Part Number	Length in. (mm)	Shipping Weight lbs (kg)
NW16	¼ in.	KASW025016	1.47 (37.3)	0.2 (0.11)
NW25	¼ in.	KASW025025	1.47 (37.3)	0.2 (0.11)
NW40	¼ in.	KASW025040	1.47 (37.3)	0.2 (0.11)
NW50	¼ in.	KASW025050	1.47 (37.3)	0.2 (0.11)
NW16	⅜ in.	KASW037516	1.63 (41.4)	0.2 (0.11)
NW25	⅜ in.	KASW037525	1.63 (41.4)	0.2 (0.11)
NW40	⅜ in.	KASW037540	1.63 (41.4)	0.2 (0.11)
NW50	⅜ in.	KASW037550	1.63 (41.4)	0.2 (0.11)
NW16	½ in.	KASW050016	1.77 (45.0)	0.2 (0.11)
NW25	½ in.	KASW050025	1.77 (45.0)	0.2 (0.11)
NW40	½ in.	KASW050040	1.77 (45.0)	0.5 (0.22)
NW50	½ in.	KASW050050	1.77 (45.0)	0.5 (0.22)
NW40	½ in.	KASW075040	2.14 (54.4)	0.5 (0.22)
NW50	½ in.	KASW075050	2.14 (54.4)	0.5 (0.22)
NW40	1 in.	KASW100040	2.60 (66.0)	0.5 (0.22)
NW50	1 in.	KASW100050	2.60 (66.0)	0.5 (0.22)

Adapters: KF to VCR – Male & Female

NOTE • KF flanges are 304L stainless steel



Ordering Information

Flange Size	Tube Size	Part Number	Length in. (mm)	Shipping Weight lbs (kg)
Male				
NW16	¼ in.	KAVM025016	1.46 (37.1)	0.2 (0.11)
NW25	¼ in.	KAVM025025	1.46 (37.1)	0.2 (0.11)
NW40	¼ in.	KAVM025040	1.46 (37.1)	0.2 (0.11)
NW16	½ in.	KAVM050016	1.65 (41.9)	0.2 (0.11)
NW25	½ in.	KAVM050025	1.65 (41.9)	0.2 (0.11)
NW40	½ in.	KAVM050040	1.65 (41.9)	0.5 (0.22)
NW16	¾ in.	KAVM075016	2.15 (54.6)	0.2 (0.11)
NW25	¾ in.	KAVM075025	2.15 (54.6)	0.2 (0.11)
NW40	¾ in.	KAVM075040	2.15 (54.6)	0.5 (0.22)
Female				
NW16	¼ in.	KAVF025016	1.46 (37.1)	0.2 (0.11)
NW25	¼ in.	KAVF025025	1.46 (37.1)	0.2 (0.11)
NW40	¼ in.	KAVF025040	1.46 (37.1)	0.2 (0.11)
NW16	½ in.	KAVF050016	1.65 (41.9)	0.2 (0.11)
NW25	½ in.	KAVF050025	1.65 (41.9)	0.2 (0.11)
NW40	½ in.	KAVF050040	1.65 (41.9)	0.5 (0.22)
NW16	¾ in.	KAVF075016	2.15 (54.6)	0.2 (0.11)
NW25	¾ in.	KAVF075025	2.15 (54.6)	0.2 (0.11)
NW40	¾ in.	KAVF075040	2.15 (54.6)	0.5 (0.22)

PVC Cord-Reinforced Flexible Vacuum Hose



Features

- Lightweight
- Transparent
- Smooth surface inside and out

Technical Specifications

Vacuum Range

To 1×10^7

Temperature Range

-25° C to 45° C

Ordering Information

Part Number	I.D. in.	O.D. in.	Weight lbs (kg)
Flexible Vacuum Hose			
HFP075	0.75	1.00	0.2 (0.11)
HFP100	1.00	1.25	0.2 (0.11)
HFP125	1.25	1.62	0.2 (0.11)
HFP150	1.50	1.87	0.2 (0.11)
HFP200	2.00	2.50	0.2 (0.11)

Part Number	Size Range	Weight lbs (kg)
Steel Worm Gear Hose Clamps		
HFPC056	1/16 in. to 1 1/4 in.	0.5 (0.22)
HFPC075	3/4 in. to 1 3/4 in.	0.5 (0.22)
HFPC131	1 5/16 in. to 2 1/4 in.	0.5 (0.22)
HFPC156	1 9/16 in. to 2 1/2 in.	0.5 (0.22)

NOTE • 10 per package

Aluminum Male Rubber Hose Adapter

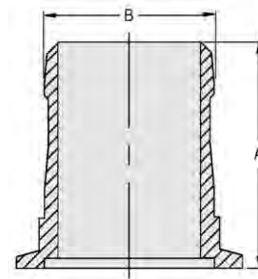

Ordering Information

Flange Size	Hose Size in.	Part Number	A in.	B in.	Weight lbs (kg)
NW16	0.50 – 0.62	KAH16050A	1.65	0.625	0.5 (0.11)
NW16	0.62 – 0.75	KAH16075A	1.65	0.750	0.5 (0.11)
NW25	0.75 – 0.87	KAH25075A	1.73	0.875	0.5 (0.11)
NW40	1.50 – 1.62	KAH40150A	2.17	1.630	0.5 (0.11)
NW50	1.50 – 1.62	KAH50150A	2.17	1.630	0.5 (0.11)

Agilent ISO Flanges and Fittings

Agilent’s introduction of its extensive offering in vacuum flanges and fittings features an intuitive part numbering format. These part numbering format allows the customer to identify the product by the characters contained within the part number.

Depending on the product, the number and format of the characters in the part number will vary. Please see examples below:

ISO Flange Example

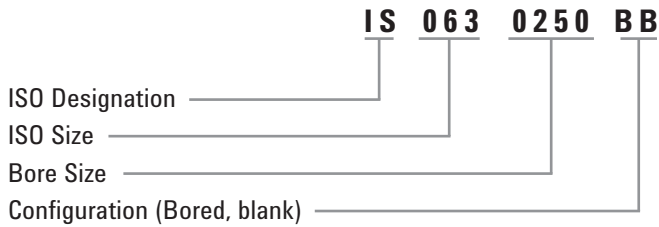

ISO 80 to 63



ISO flanges and fittings are designed for applications requiring frequent disassembly and where tubing requirements generally exceed 2 in. OD. All ISO flanges and fittings listed are made of 304L stainless steel. These flanges can be used in a variety of applications from atmospheric to E-8 Torr. They can sustain a bakeout temperature of 150° C when using Viton o-rings.

ISO-Flanges & Fittings

Page

Flange Fastening Options	78
MF Flanges	79
Bolted Flanges	80
Bolt Sets.....	80
Bolted Tapped Flanges.....	81
Bolt Sets for Tapped Flanges	81
Centering Rings.....	82
Clamps.....	83
O-Rings.....	85
Weld Stubs	86
Half Nipples	87
Nipples	87
Elbows	88
Tees.....	88
4-Way Cross	89
Reducing Nipple.....	89
Flexible Couplings.....	90
Conical Reducers.....	91
Adapters, ISO to ConFlat.....	92
Adapters, ISO to KF.....	93

ISO Flanges & Fittings

Flange Fastening Options

Flanges are available in these bolting/clamping options:
Clamped Flanges (also called MF Flanges or Multi-Fastener) are fastened to each other with Double-Claw Clamps (Fig. 1), or to bolted tapped flanges with Single-Claw Clamps (Fig. 2). Bolted Flanges may be fastened to each other with Nut/Bolt Sets (Fig. 3), or bolted to ISO Bolted Tapped Flanges (Fig. 4).

NOTE - At 10" (NW250) and above, some manufacturers standards vary. Please check dimensions carefully.

Flange Fastening Options

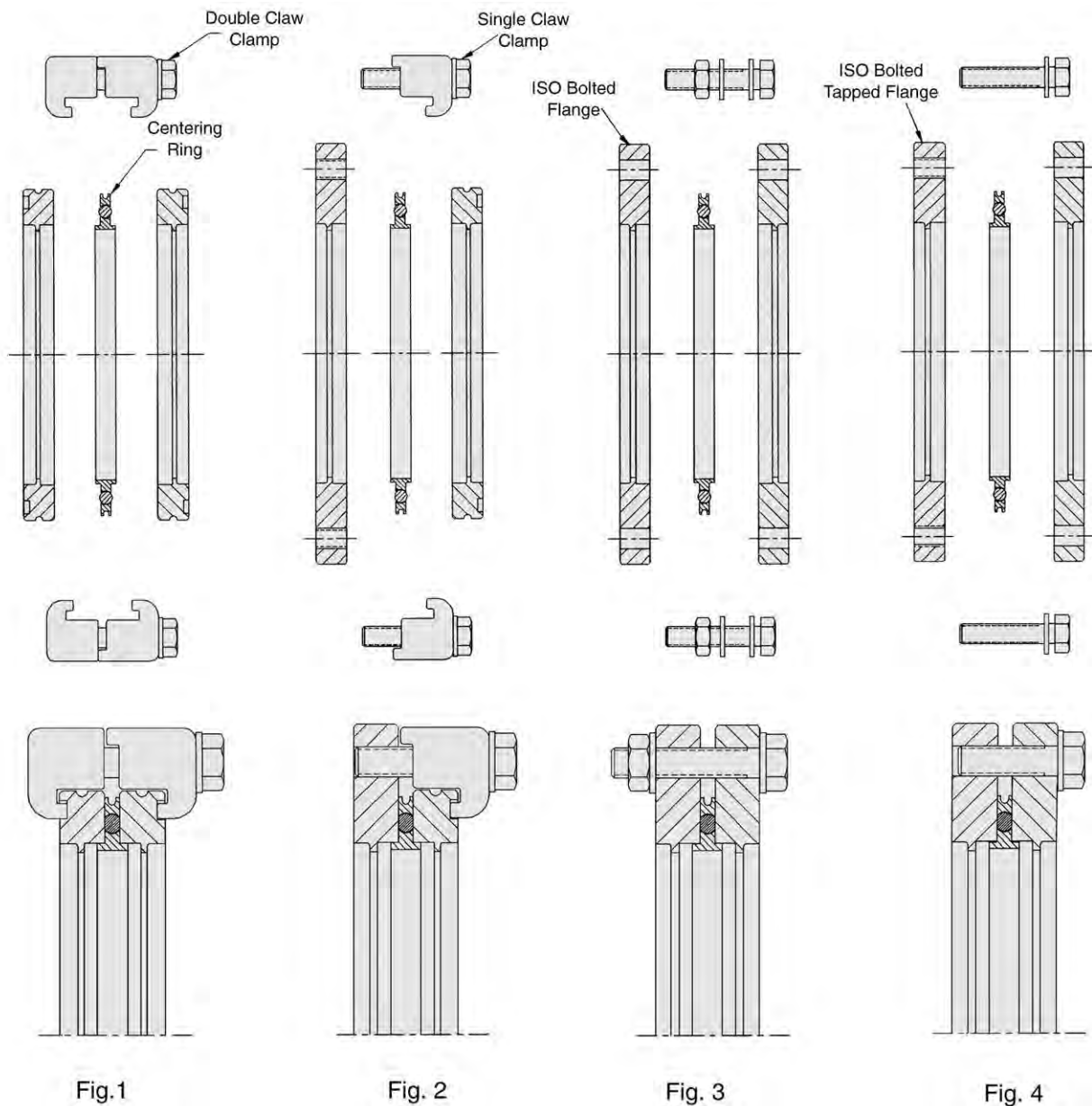

Components

MF Flanges-Bored

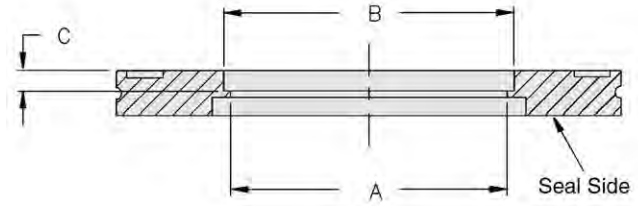

Ordering Information

Size	Part Number	Nominal Bore	A in. (mm)	B in. (mm)	C in. (mm)	Shipping Weight lbs (kg)
NW63	IS0630250BB	2.5 in.	2.37 (60.2)	2.53 (63.8)	0.22 (5.6)	1.0 (0.5)
NW100	IS1000400BB	4.0 in.	3.84 (97.5)	4.03 (101.9)	0.22 (5.6)	1.0 (0.5)
NW160	IS1600600BB	6.0 in.	5.85 (148.6)	6.03 (152.7)	0.22 (5.6)	2.0 (0.9)
NW200	IS2000800BB	8.0 in.	7.85 (199.4)	8.03 (203.5)	0.22 (5.6)	3.0 (1.4)
NW250	IS2501000BB	10.0 in.	9.86 (250.4)	10.04 (254.3)	0.22 (5.6)	4.0 (1.8)

MF Flanges-Blank

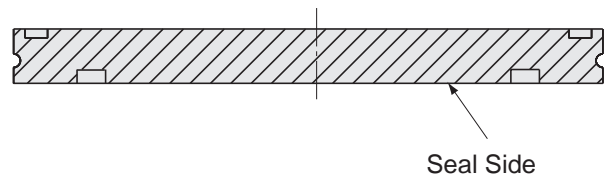

Ordering Information

Size	Part Number	Outer Diameter	Thickness	Shipping Weight lbs (kg)
NW63	IS0630000BL	3.74 (95.0)	0.47 (12.0)	1.0 (0.5)
NW100	IS1000000BL	5.12 (130.0)	0.47 (12.0)	2.5 (1.1)
NW160	IS1600000BL	7.09 (180.0)	0.47 (12.0)	5.0 (2.3)
NW200	IS2000000BL	9.45 (240.0)	0.47 (12.0)	8.0 (3.6)
NW250	IS2500000BL	11.42 (290.0)	0.47 (12.0)	13.0 (5.9)

ISO Flanges & Fittings

Bolted Clear Hole Flanges

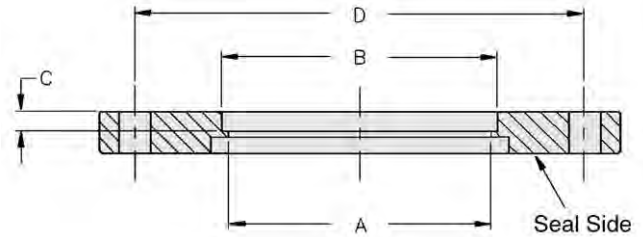

Ordering Information – Bolted Flanges-Bored

Size	Part Number	Nominal Bore	A in. (mm)	B in. (mm)	C in. (mm)	D in. (mm)	Bolt Holes	Weight lbs (kg)
NW63	IS0630250BBB	2.5 in.	2.37 (60.2)	2.53 (63.8)	0.22 (5.6)	4.33 (110.0)	4 x M9	0.50 (0.2)
NW100	IS1000400BBB	4.0 in.	3.83 (97.5)	4.03 (101.9)	0.22 (5.6)	5.71 (145.0)	8 x M9	1.00 (0.5)
NW160	IS1600600BBB	6.0 in.	5.83 (148.6)	6.03 (152.7)	0.22 (5.6)	7.87 (200.0)	8 x M11	1.50 (0.7)
NW200	IS2000800BBB	8.0 in.	7.83 (199.4)	8.03 (203.5)	0.22 (5.6)	10.24 (260.0)	12 x M11	2.00 (0.9)
NW250	IS2501000BBB	10.0 in.	9.76 (250.4)	10.04 (254.3)	0.22 (5.6)	12.20 (310.0)	12 x M11	3.00 (1.4)

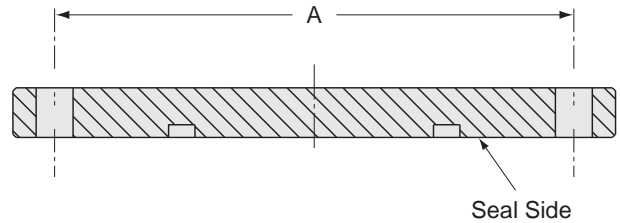

Ordering Information – Bolted Flanges-Blank

Size	Part Number	A in. (mm)	Bolt Holes	Shipping Weight lbs (kg)
NW63	IS0630000BLB	4.33 (110.0)	4 x M9	1.0 (0.5)
NW100	IS1000000BLB	5.71 (145.0)	8 x M9	2.5 (1.1)
NW160	IS1600000BLB	7.87 (199.9)	8 x M11	5.0 (2.3)
NW200	IS2000000BLB	10.24 (260.1)	12 x M11	8.0 (3.6)
NW250	IS2500000BLB	12.20 (309.9)	12 x M11	13.0 (5.9)

Bolt Sets for Clear Hole Flanges

Ordering Information

Size	Part Number	Bolt Size	Qty/Pack	Shipping Weight lbs (kg)
NW63	IB063	M8 x 45 mm	4	0.25 (0.1)
NW80, NW100	IB080100	M8 x 45 mm	8	0.50 (0.2)
NW160	IB160	M10 x 50 mm	8	0.50 (0.2)
NW200, NW250	IB200250	M10 x 50 mm	12	0.75 (0.3)

Components

Bolted Tapped Flanges

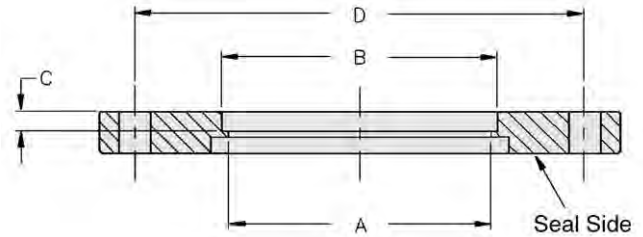

Ordering Information

Size	Part Number	Nominal Bore	A in. (mm)	B in. (mm)	C in. (mm)	D in. (mm)	Bolt Holes	Weight lbs (kg)
NW63	IS0630250BBBT	2.5 in.	2.37 (60.2)	2.53 (63.8)	0.22 (5.6)	4.33 (110.0)	4 x M8	0.50 (0.2)
NW100	IS1000400BBBT	4.0 in.	3.83 (97.5)	4.03 (101.9)	0.22 (5.6)	5.71 (145.0)	8 x M8	1.00 (0.5)
NW160	IS1600600BBBT	6.0 in.	5.83 (148.6)	6.03 (152.7)	0.22 (5.6)	7.87 (200.0)	8 x M10	1.50 (0.7)
NW200	IS2000800BBBT	8.0 in.	7.83 (199.4)	8.03 (203.5)	0.22 (5.6)	10.24 (260.0)	12 x M10	2.00 (0.9)
NW250	IS2501000BBBT	10.0 in.	9.76 (250.4)	10.04 (254.3)	0.22 (5.6)	12.20 (310.0)	12 x M10	3.00 (1.4)

Bolt Sets for Tapped Flanges

Ordering Information

Size	Part Number	Bolt Size	Qty/Pack	Shipping Weight lbs (kg)
NW63	IB063T	M8 x 30 mm	4	0.25 (0.1)
NW80, NW100	IB080100T	M8 x 30 mm	8	0.50 (0.2)
NW160	IB160T	M10 x 35 mm	8	0.50 (0.2)
NW200, NW250	IB200250T	M10 x 35 mm	12	0.75 (0.3)

Centering Rings

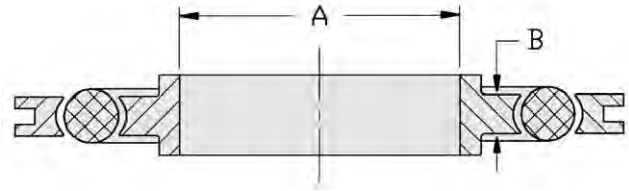

Ordering Information – Aluminum Ring, Viton O-Ring

Size	Part Number	A in. (mm)	B in. (mm)	Shipping Weight lbs (kg)
NW63	IC063AV	2.62 (66.8)	0.15 (3.8)	1.0 (0.5)
NW80	IC080AV	3.13 (79.8)	0.15 (3.8)	1.0 (0.5)
NW100	IC100AV	3.88 (98.8)	0.15 (3.8)	1.0 (0.5)
NW160	IC160AV	5.87 (149.9)	0.15 (3.8)	1.0 (0.5)
NW200	IC200AV	8.24 (209.8)	0.15 (3.8)	1.0 (0.5)
NW250	IC250AV	10.13 (257.6)	0.15 (3.8)	1.0 (0.5)

Ordering Information – Aluminum Ring, Buna-N O-Ring

Size	Part Number	A in. (mm)	B in. (mm)	Shipping Weight lbs (kg)
NW63	IC063AB	2.62 (66.8)	0.15 (3.8)	1.0 (0.5)
NW80	IC080AB	3.13 (79.8)	0.15 (3.8)	1.0 (0.5)
NW100	IC100AB	3.88 (98.8)	0.15 (3.8)	1.0 (0.5)
NW160	IC160AB	5.87 (149.9)	0.15 (3.8)	1.0 (0.5)
NW200	IC200AB	8.24 (209.8)	0.15 (3.8)	1.0 (0.5)
NW250	IC250AB	10.13 (257.6)	0.15 (3.8)	1.0 (0.5)

Ordering Information – Stainless Steel Ring, Viton O-Ring

Size	Part Number	A in. (mm)	B in. (mm)	Shipping Weight lbs (kg)
NW63	IC063SV	2.62 (66.8)	0.15 (3.8)	1.0 (0.5)
NW80	IC080SV	3.13 (79.8)	0.15 (3.8)	1.0 (0.5)
NW100	IC100SV	3.88 (98.8)	0.15 (3.8)	1.0 (0.5)
NW160	IC160SV	5.87 (149.9)	0.15 (3.8)	1.0 (0.5)
NW200	IC200SV	8.24 (209.8)	0.15 (3.8)	1.0 (0.5)
NW250	IC250SV	10.13 (257.6)	0.15 (3.8)	1.0 (0.5)

Modified ISO Claw Clamps

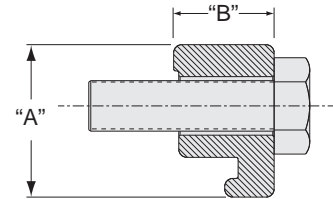
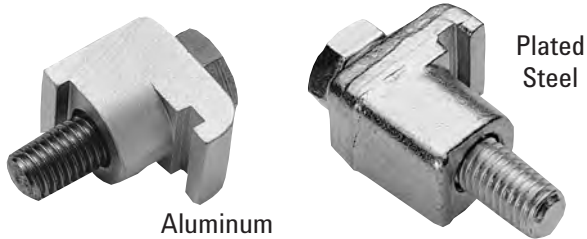

Figure 1

Features

- Heavy duty material
- Suitable for mounting equipment in any orientation and tight geometrics

Ordering Information – Single Claw Clamp – For use with a Standard ISO Flange and Centering Ring (NOT for Turbo Pumps)

Size	Figure	Part Number	Per Package	A in. (mm)	B in. (mm)	Bolt Size	Shipping Weight lbs (kg)
NW63/100	1	ICS063100CC22X5S	4	0.925 (23.5)	0.87 (22.5)	M8 x 35 mm	1.0 (0.50)
NW160/250	1	ICS160250CC23X0A*	1	1.126 (28.6)	0.91 (23.1)	M10 x 35 mm	0.5 (0.20)

* Aluminum

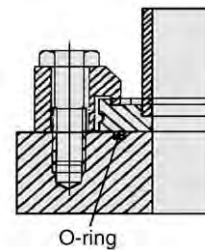
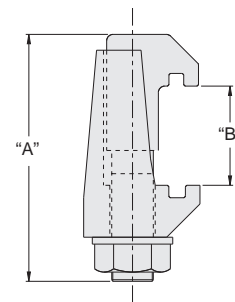
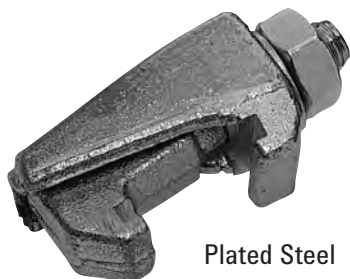

Figure 2

Ordering Information – Single Claw Clamp – For use with a Flange and Base Plate with Sealing Groove and O-ring (NOT for Turbo Pumps)

Size	Figure	Part Number	Per Package	A in. (mm)	B in. (mm)	Bolt Size	Shipping Weight lbs (kg)
NW160/250	1 & 2	ICS160250CC19X1S	1 & 2	1.14 (28.8)	.75 (19.1)	M10 x 35 mm	1.0 (0.5)



Ordering Information – Tapered Claw Clamp, ISO 63/250 (Suitable for Agilent Turbo Pumps)

Size	Part Number	A in. (mm)	B in. (mm)	Bolt Size	Shipping Weight lbs (kg)
NW63/250	IC63250DCMZ	2.34 (59.5)	0.67/1.05 (17.0/27)	M10	1.0 (0.5)

ISO Flanges & Fittings

Standard ISO Claw Clamps

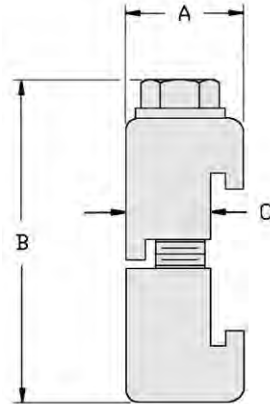
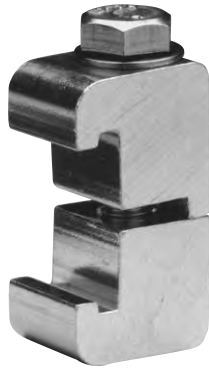

Ordering Information – Double Claw (NOT for Turbo Pumps)

Size	Part Number	A in. (mm)	B in. (mm)	C in. (mm)	Shipping Weight lbs (kg)
For flange sizes NW63, 080, 100	IC063100A	0.95 (24.1)	1.98 (50.3)	0.63 (16.0)	0.5 (0.2)
For flange sizes NW160, 200, 250	IC160250A	1.10 (27.9)	2.05 (52.1)	0.80 (20.3)	0.5 (0.2)
For flange sizes NW400, 500	IC400500A	1.34 (34.0)	2.56 (65.0)	1.04 (26.4)	0.5 (0.2)

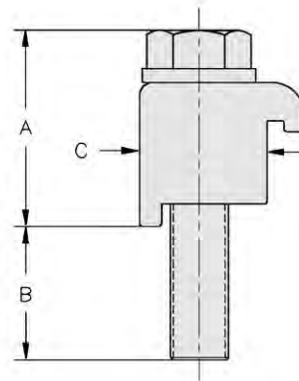
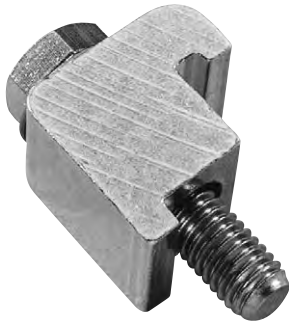

Ordering Information – Single Claw (NOT for Turbo Pumps)

Size	Part Number	A in. (mm)	B in. (mm)	C in. (mm)	Shipping Weight lbs (kg)
For flange sizes NW63, 080, 100	ICS063100A	1.20 (30.4)	0.39 (9.9)	0.63 (16.0)	0.5 (0.2)
For flange sizes NW160, 200, 250	ICS160250A	1.25 (31.7)	0.39 (9.9)	0.80 (20.3)	0.5 (0.2)

NOTE • Use the chart below to determine proper quantities for all clamps on pages 83 and 84.

Flange Size	# of Clamps
NW63	4
NW100-160	8
NW250	12

Components

O-Rings

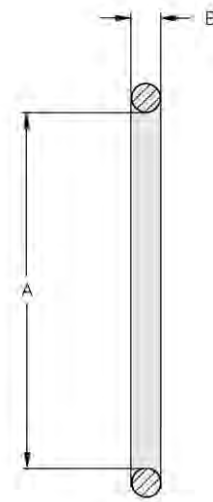
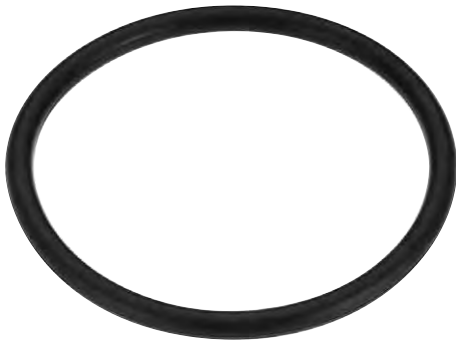

Ordering Information – Viton

Size	Part Number	A in. (mm)	B in. (mm)	Shipping Weight lbs (kg)
NW63	IO063V	2.85 (72.4)	0.21 (5.33)	0.25 (0.1)
NW80	IO080V	3.35 (85.1)	0.21 (5.33)	0.25 (0.1)
NW100	IO100V	4.10 (104.1)	0.21 (5.33)	0.25 (0.1)
NW160	IO160V	5.98 (151.9)	0.21 (5.33)	0.25 (0.1)
NW200	IO200V	8.48 (215.4)	0.21 (5.33)	0.25 (0.1)
NW250	IO250V	10.50 (266.2)	0.21 (5.33)	0.25 (0.1)

Ordering Information – Silicone

Size	Part Number	A in. (mm)	B in. (mm)	Shipping Weight lbs (kg)
NW63	IO063S	2.85 (72.4)	0.21 (5.3)	0.25 (0.1)
NW100	IO100S	4.10 (104.1)	0.21 (5.3)	0.25 (0.1)
NW160	IO160S	5.98 (151.9)	0.21 (5.3)	0.25 (0.1)

ISO Flanges & Fittings

Weld Stubs

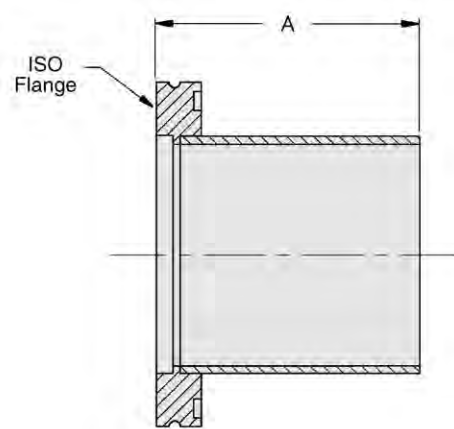

Ordering Information – Weld Stubs, MF Flanges

Size	Part Number	Tube Size	A in. (mm)	Shipping Weight lbs (kg)
NW63	IWS063	2.5 in.	3.94 (100.1)	1.0 (0.5)
NW100	IWS100	4.0 in.	3.94 (100.1)	2.0 (0.9)
NW160	IWS160	6.0 in.	3.94 (100.1)	3.0 (1.4)

Ordering Information – Weld Stubs, Bolted Flanges

Size	Part Number	Tube Size	A in. (mm)	Shipping Weight lbs (kg)
NW63	IWS063B	2.5 in.	3.94 (100.1)	1.0 (0.5)
NW100	IWS100B	4.0 in.	3.94 (100.1)	2.0 (0.9)
NW160	IWS160B	6.0 in.	3.94 (100.1)	3.0 (1.4)

Half Nipples

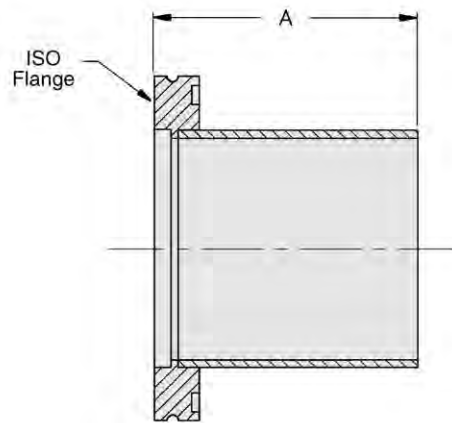

Ordering Information

Size	Part Number	Tube Size	A in. (mm)	Shipping Weight lbs (kg)
NW63	INH0630250	2.5 in.	4.00 (101.6)	1.0 (0.5)
NW100	INH1000400	4.0 in.	5.12 (130.0)	2.0 (0.9)
NW100	INH1000400S	4.0 in.	3.00 (76.2)	2.0 (0.9)
NW160	INH1600600	6.0 in.	6.31 (160.3)	4.0 (1.8)

Nipples

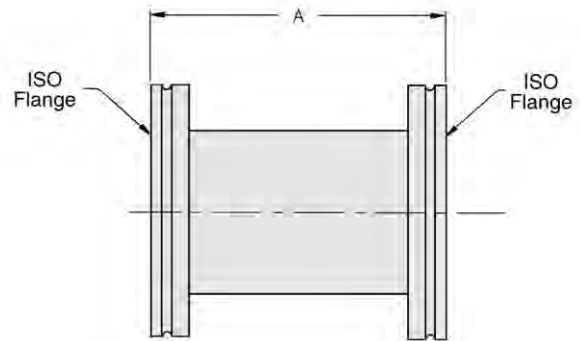

Ordering Information

Size	Part Number	Tube Size	A in. (mm)	Shipping Weight lbs (kg)
NW63	INF0630250	2.5 in.	8.00 (203.2)	2.0 (0.9)
NW100	INF1000400	4.0 in.	10.24 (260.1)	3.0 (1.4)
NW160	INF1600600	6.0 in.	12.62 (320.5)	8.0 (3.6)

ISO Flanges & Fittings

Elbows 90°

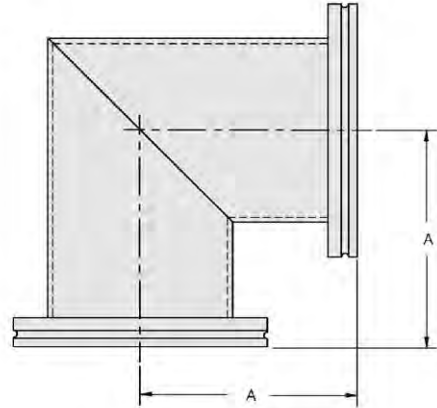

Ordering Information

Size	Part Number	Tube Size	A in. (mm)	Shipping Weight lbs (kg)
NW63	IE02500346	2.5 in.	3.46 (87.9)	2.0 (0.9)
NW100	IE04000425	4.0 in.	4.25 (108.0)	6.0 (2.7)
NW160	IE06000543	6.0 in.	5.43 (137.9)	10.0 (4.5)

Tees

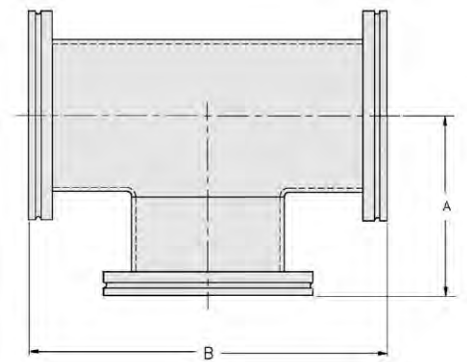

Ordering Information

Size	Part Number	Tube Size	A in. (mm)	B in. (mm)	Shipping Weight lbs (kg)
NW63	IT02500346	2.5 in.	3.46 (87.9)	6.92 (175.8)	3.0 (1.4)
NW100	IT04000425	4.0 in.	4.25 (108.0)	8.50 (215.9)	8.0 (3.6)
NW160	IT06000543	6.0 in.	5.43 (137.9)	10.86 (275.8)	13.0 (5.9)

Components

4-Way Cross

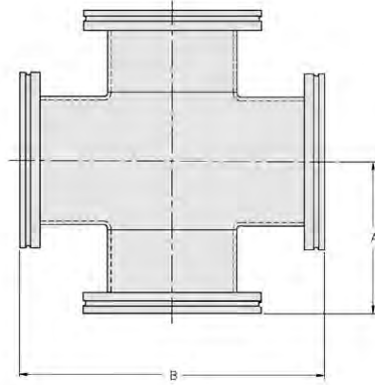

Ordering Information

Size	Part Number	Tube Size	A in. (mm)	B in. (mm)	Shipping Weight lbs (kg)
NW63	IC02500346	2.5 in.	3.46 (87.9)	6.92 (175.8)	6.0 (2.7)
NW100	IC04000425	4.0 in.	4.25 (108.0)	8.50 (215.9)	10.0 (4.5)
NW160	IC06000543	6.0 in.	5.43 (137.9)	10.86 (275.8)	15.0 (6.8)

Reducing Nipple

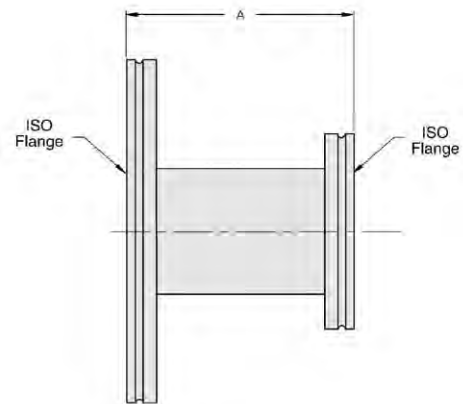

Ordering Information

Size	Part Number	Tube Size	A in. (mm)	Shipping Weight lbs (kg)
NW80-63	INR080063	2.5 in.	4.0 (101.6)	3.0 (1.4)
NW100-63	INR100063	2.5 in.	4.0 (101.6)	4.5 (2.0)
NW100-80	INR100080	3.0 in.	4.0 (101.6)	5.0 (7.3)
NW160-63	INR160063	2.5 in.	4.0 (101.6)	6.0 (2.7)
NW160-100	INR160100	4.0 in.	4.0 (101.6)	10.5 (4.8)
NW200-160	INR200160	6.0 in.	4.0 (101.6)	13.5 (6.1)
NW250-200	INR250200	8.0 in.	4.0 (101.6)	18.0 (8.2)

Flexible Couplings

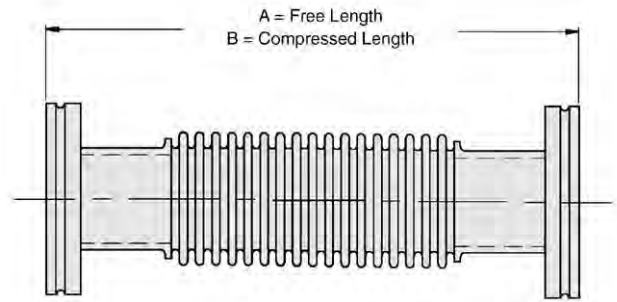

Features

- Bellows Material: Type 321 SS

Ordering Information – Flexible Couplings, Non-Braided, ISO

Flange Size	Part Number	Length Free A in. (mm)	Length Compressed B in. (mm)	Static Bend Radius in. (mm)	Bellows Wall Thickness in.	Nominal ID in. (mm)	Shipping Weight lbs (kg)
ISO63	IL02000600	6.0 (152)	5.5 (140)	10.0 (254)	0.006	2.5 (64)	2.0 (0.9)
	IL02001200	12.0 (305)	10.9 (277)	10.0 (254)	0.006	2.5 (64)	2.0 (0.9)
	IL02502000	20.0 (508)	18.1 (461)	3.2 (81)	0.015	2.5 (64)	3.0 (1.4)
	IL02503000	30.0 (762)	24.0 (610)	3.2 (81)	0.015	2.5 (64)	3.0 (1.4)
	IL02504000	40.0 (1016)	36.1 (917)	3.2 (81)	0.015	2.5 (64)	4.0 (1.8)
ISO100	IL04000600	6.0 (152)	5.5 (141)	16.0 (406)	0.016	3.5 (89)	3.0 (1.4)
	IL04001200	12.0 (305)	10.9 (277)	19.0 (483)	0.010	4.0 (102)	4.0 (1.8)
	IL04002000	20.0 (508)	18.1 (460)	4.5 (114)	0.016	4.0 (102)	4.0 (1.8)
	IL04003000	30.0 (762)	27.1 (688)	4.5 (114)	0.016	4.0 (102)	5.0 (2.3)
	IL04004000	40.0 (1016)	36.1 (917)	4.5 (114)	0.016	4.0 (102)	5.0 (2.3)
ISO160	IL06000600	6.0 (152)	5.5 (140)	21.0 (533)	0.010	6.0 (152)	4.0 (1.8)
	IL06001200	12.0 (305)	10.9 (277)	21.0 (533)	0.010	6.0 (152)	5.0 (2.3)

Conical Reducers

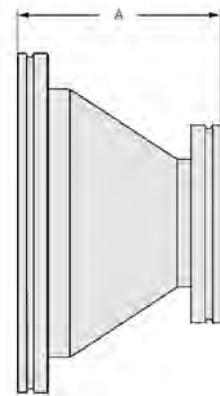

Ordering Information

Size	Part Number	A in. (mm)	Shipping Weight lbs (kg)
NW80-63	IRC080063	4.13 (104.9)	3.5 (1.6)
NW100-63	IRC100063	4.13 (104.9)	4.5 (2.0)
NW100-80	IRC100080	4.13 (104.9)	4.5 (2.0)
NW160-80	IRC160080	9.50 (241.3)	5.0 (2.3)
NW160-100	IRC160100	9.50 (241.3)	5.0 (2.3)

Conical Reducers – ISO to KF

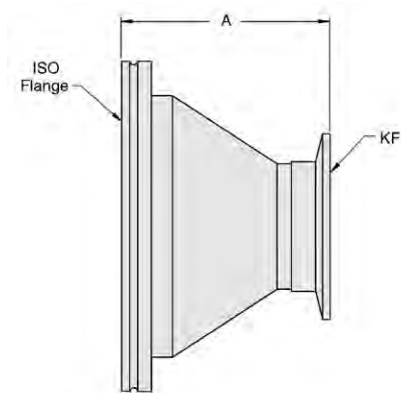

Ordering Information

Size	Part Number	A in. (mm)	Shipping Weight lbs (kg)
NW63-NW40	IKRC063040	2.84 (72.1)	1.5 (0.7)
NW63-NW50	IKRC063050	2.85 (72.4)	2.5 (1.1)
NW80-NW40	IKRC080040	4.09 (103.9)	3.0 (1.4)
NW80-NW50	IKRC080050	4.10 (104.1)	3.0 (1.4)
NW100-NW50	IKRC100050	4.10 (104.1)	3.5 (1.6)

Adapters – ISO to ConFlat

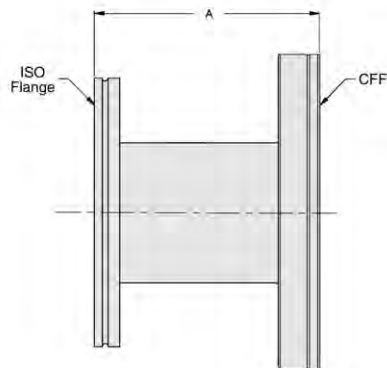

Ordering Information

Size	Part Number	Tube Size	A in. (mm)	Shipping Weight lbs (kg)
NW63-4.5 in. CFF	IFA0630450	2.5 in.	4.13 (104.9)	3.5 (1.6)
NW80-6 in. CFF	IFA0800600	3.0 in.	4.19 (106.4)	4.0 (1.8)
NW100-6 in. CFF	IFA1000600	4.0 in.	4.19 (106.4)	5.5 (2.5)
NW160-8 in. CFF	IFA1600800	6.0 in.	4.25 (108.0)	9.0 (4.1)
NW200-10 in. CFF	IFA2001000	8.0 in.	4.25 (108.0)	16.0 (7.2)

Adapters – ISO to KF, Short and Long

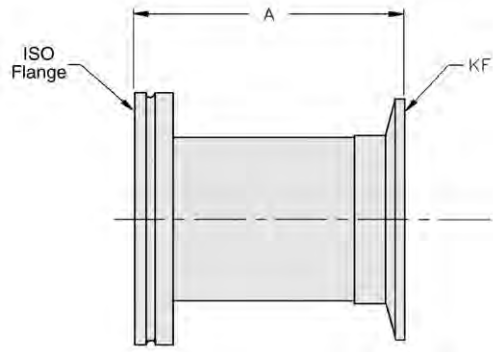

Ordering Information

Size	Part Number	Tube Size	A in. (mm)	Shipping Weight lbs (kg)
Long				
NW63-NW40	IKA063040L	1.50 in.	2.71 (68.8)	1.0 (0.5)
NW63-NW50	IKA063050L	2.00 in.	3.46 (87.9)	1.5 (0.7)
NW80-NW40	IKA080040L	1.50 in.	2.71 (68.8)	1.5 (0.7)
NW80-NW50	IKA080050L	2.00 in.	3.46 (87.9)	1.5 (0.7)
Short				
NW63-NW16	IKA063016S	0.75 in.	1.75 (44.5)	1.0 (0.5)
NW63-NW25	IKA063025S	1.00 in.	1.75 (44.5)	1.0 (0.5)
NW63-NW40	IKA063040S	1.50 in.	1.75 (44.5)	1.0 (0.5)
NW63-NW50	IKA063050S	2.00 in.	1.75 (44.5)	1.5 (0.7)
NW80-NW25	IKA080025S	1.00 in.	1.75 (44.5)	1.5 (0.7)
NW80-NW40	IKA080040S	1.50 in.	1.75 (44.5)	1.5 (0.7)
NW80-NW50	IKA080050S	2.00 in.	1.75 (44.5)	2.0 (0.9)
NW100-NW25	IKA100025S	1.00 in.	1.75 (44.5)	2.0 (0.9)
NW100-NW40	IKA100040S	1.50 in.	1.75 (44.5)	2.0 (0.9)
NW100-NW50	IKA100050S	2.00 in.	1.75 (44.5)	2.5 (1.1)
NW160-NW40	IKA160040S	1.50 in.	1.75 (44.5)	5.0 (2.3)
NW160-NW50	IKA160050S	2.00 in.	1.75 (44.5)	6.0 (2.7)

Feedthroughs

Rotary Motion Feedthrough

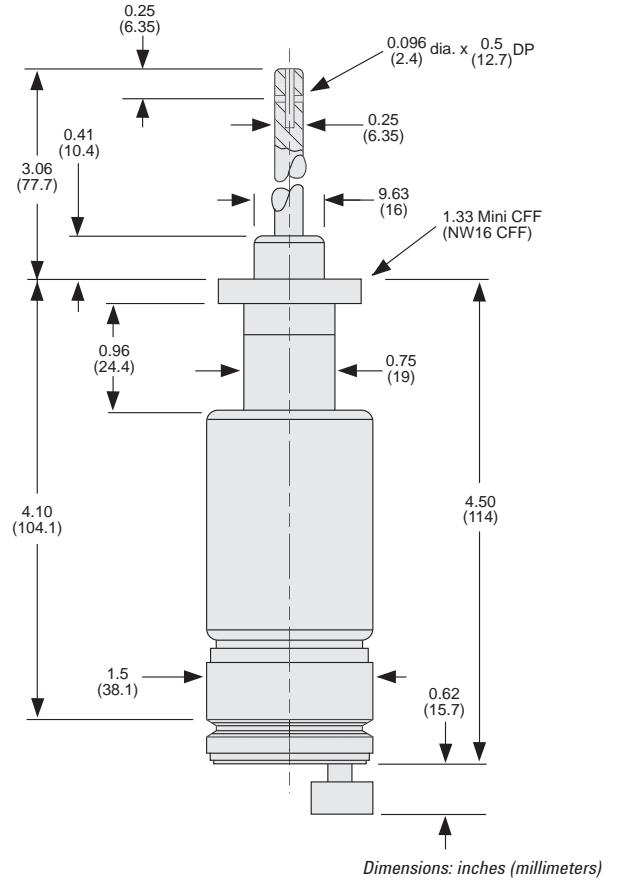

Especially well-suited for bakeable ultra-high vacuum applications, this rotary motion feedthrough is bellows-sealed and has a built-in lock. It is mounted on a 1.33 in. OD Mini-ConFlat flange (NW16 CFF).

Technical Specifications

Vacuum Range	Atmosphere to 10^{-11} Torr (mbar)
Torque Rating	150 inch-ounces
Speed	200 RPM maximum
Runout at Shaft Tip	0.006" maximum (0.15 mm)
Life	50,000 total turns nominal 300° C maximum (bakeout)
Temperature	-196° C to +150° C (operating)
Rotation	Continuously rotatable in either direction

Ordering Information

Description	Part Number	Shipping Weight lbs (kg)
Rotary motion feedthrough		
On 1 1/2 in. mini ConFlat flange (NW16 CFF)	L6691301	5.0 (2.3)
Gaskets for mini ConFlat flange (NW16 CFF), 10/pkg	FG0133CI	1.0 (0.5)

High Voltage Feedthroughs

This high voltage feedthrough is rated at up to 12 kV (below 10^{-4} Torr/mbar) and is provided with a Mini (1.33 in.) ConFlat® flange (NW16 CFF).

12 kV Fischer Feedthrough on Mini-ConFlat Flange

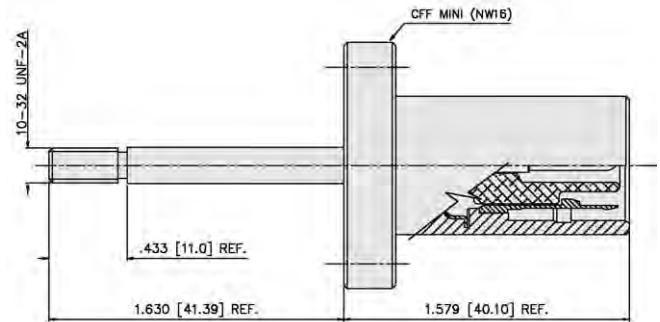

Dimensions: inches (millimeters)

Technical Specifications

Voltage Rating (below 10^{-4} Torr/mbar)	12 kV F/T Fischer
Current Rating	1A maximum
Temperature Range	-196° C to +450° C
Body Material	Stainless Steel
Mounting Flange	1.33 in. O.D. mini (NW 16)

Ordering Information

Description	Part Number	Shipping Weight lbs (kg)
High voltage feedthrough, vacuum side mating connector, With 1 1/2 in. Mini-ConFlat flange (NW16 CFF) (for Star-Cell Ion pumps, cables and connectors please see the Ion Pumps section) (external connector not included, please order separately)	9595125	1.0 (0.5)
Gaskets for Mini-ConFlat flange (NW16 CFF) 10/pkg	FG0133CI	1.0 (0.5)

Supplies

Supplies	Page
Greases and lubricants	97
Mechanical pump fluids	98

Greases and Lubricants

Torr Seal Low Vapor Pressure Resin Sealant



Torr Seal epoxy resin quickly seals leaks on any type of vacuum system or component. Provided in convenient tubes, Torr Seal is solvent-free and can be used at pressures of 10^{-9} Torr (mbar) and below, at temperatures from -45°C to 120°C (bakeable temperature). Additionally, Torr Seal permits leak checking immediately after curing and bonds with many materials including metal, ceramic, and glass.

Ordering Information

Description	Part Number	Weight lbs (kg)
Torr Seal base resin, 90 grams, and Torr Seal hardener, 45 grams	9530001	1.0 (0.45)

Torr Seal Mixing System



The Torr Seal Mixing System includes an applicator gun, a premeasured Torr Seal cartridge, and an epoxy/resin mixer. The system uses the same low vapor pressure resin sealant as standard Torr Seal, while providing a systematic and scientific way of mixing the Torr Seal epoxy and resin. The applicator gun dispenses premeasured epoxy and resin from the cartridge through the mixer so that a uniform Torr Seal bead can be placed on any surface. As with the standard Torr Seal tubes, the mixing system can be used at pressures of 10^{-9} Torr and below, and at temperatures from -45°C to 120°C (bakeable temperature).

Ordering Information

Description	Part Number	Weight lbs (kg)
Applicator gun with Torr Seal cartridge (2 oz.) and three mixers	9530002	2.00 (0.91)
Applicator gun only	9530003	1.50 (0.68)
Torr Seal cartridge (2 oz.) and three mixers	9530004	0.75 (0.34)
Mixers only (six to a package)	9530005	0.25 (0.11)

VacuumXpress

Fel-Pro Heavy Duty Anti-Seize

Fel-Pro Heavy Duty Anti-Seize is a high-temperature, anti-galling lubricant designed for screw threads and other mated components of all types. Generally used in applications that are external to vacuum systems, Fel-Pro is useful in temperature ranges of 70°C to $+1315^{\circ}\text{C}$.

Ordering Information

Description	Part Number	Weight lbs (kg)
Fel-Pro Heavy Duty Anti-Seize Lubricant	9530031	0.3 (0.13)

Apiezon Vacuum Grease, Type L

Apiezon L is a general vacuum grease that has a vapor pressure from 10^{-11} Torr (mbar) at 20°C to 10^{-3} Torr (mbar) at 300°C , and has a melting point of $< 50^{\circ}\text{C}$.

Ordering Information

Description	Part Number	Weight lbs (kg)
Apiezon L vacuum grease, 1 oz.	695400004	1.0 (0.45)

Dow Corning High Vacuum Silicone Grease

This high vacuum grease is a stiff, non-melting, non-oxidizing silicone lubricating material that maintains its consistency from -40°C to $+260^{\circ}\text{C}$.

Ordering Information

Description	Part Number	Weight lbs (kg)
High vacuum silicon grease, 5.3 oz.	695400008	1.0 (0.45)

Agilent Vacuum Grease

This is a general purpose grease with a vapor pressure in the 10^{-6} Torr range. It is a non-silicone grease that comes in two viscosities and two sizes.

Ordering Information

Description	Part Number	Weight lbs (kg)
Agilent Vacuum grease, Medium Weight, $\frac{1}{4}$ lb size	LGCMID025	1.0 (0.45)
Agilent Vacuum grease, Medium Weight, 1 lb size	LGCMID100	1.0 (0.45)
Agilent Vacuum grease, Heavy Weight, $\frac{1}{4}$ lb size	LGCHEV025	1.0 (0.45)
Agilent Vacuum grease, Heavy Weight, 1 lb size	LGCHEV100	1.0 (0.45)

Supplies

Diffusion and Mechanical Pump Fluids

Exact diffusion pump fluid charges are now available!

Agilent offers a wide range of diffusion pump fluid types and container sizes. We have just the right fluid type and container size to meet the requirements of your particular application. Agilent now offers exact pump charges for many of our diffusion pumps, including the VHS-6, VHS-10, HS-16,

HS-20, HS-32, and NHS-35. Exact pump charges enables you to purchase just enough fluid to fill your diffusion pump, thus eliminating costly waste. This eliminates problems associated with the disposal of diffusion pump fluid, and eliminates the guess work associated with filling the pump.

Ordering Information

Description	Diffusion Pump Exact Charge	Part Number	Shipping Weight lbs (kg)
NEOVAC SY*			
1 liter/1,000 cc	VHS-10, VHS-400	K6948301	3.0 (1.4)
1 U.S. gallon (3.8 liters)		K6948305	10.6 (4.8)
5 U.S. gallons (18.9 liters)		K6948315	53.0 (23.9)
Dow Corning DC-702*			
500 cc	VHS-6, VHS-250	695472005	3.0 (1.4)
1 U.S. gallon (3.8 liters)		695472008	12.0 (5.4)
5 U.S. gallons (18.9 liters)		695472015	51.0 (23.0)
Dow Corning DC-704*			
500 cc	VHS-6, VHS-250	695474005	3.0 (1.4)
1 U.S. gallon (3.8 liters)		695474008	12.0 (5.4)
6.2 U.S. gallons (23.5 liters)		695474015	51.0 (23.0)
Dow Corning DC-705*			
500 cc	VHS-6, VHS-250	695475005	3.0 (1.4)
1 U.S. gallon (3.8 liters)		695475008	12.0 (5.4)
Santovac 5			
40 cc		695405001	1.0 (0.5)
65 cc		695405002	2.0 (0.9)
500 cc	VHS-6, VHS-250	695405005	2.5 (1.1)

* For technical information, refer to the Diffusion Pump Section page 30.

Agilent Oil, GP Type Mechanical Pump Fluid

Agilent GP Type Fluid is a mechanical pump fluid recommended for use in non-corrosive applications. As a result of molecular distillation, it has low vapor pressure and, therefore, backstreams less than undistilled refinery products.

Ordering Information

Description	Part Number	Shipping Weight lbs (kg)
1 liter bottle	K7516301	3.5 (1.6)
1 gallon bottle	K7516302	14.0 (6.4)